

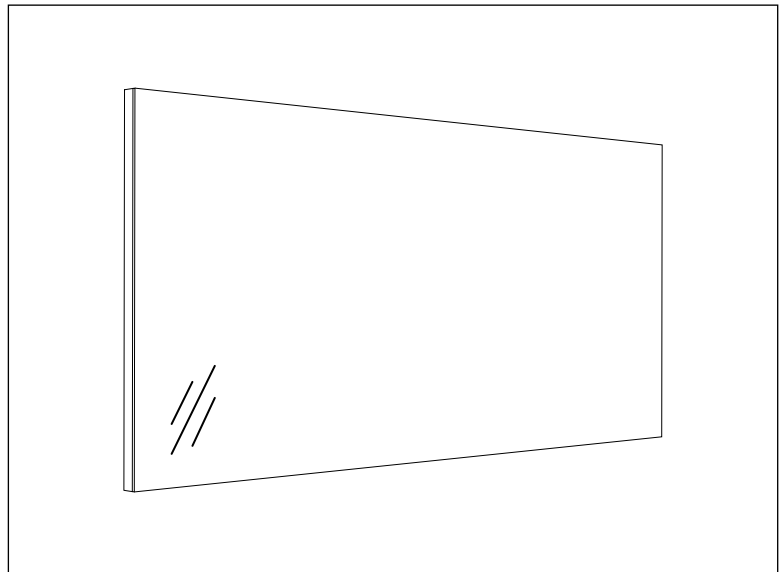









<b>101005</b> Keller Art. Nr. 600004001	Flexlight 450-600 Flexlight 450-600 Flexlight 450-600
<b>101010</b> Keller Art. Nr. 600004002	Flexlight 610-1000 Flexlight 610-1000 Flexlight 610-1000
<b>101011</b> Keller Art. Nr. 600004003	Flexlight 1010-1500 Flexlight 1010-1500 Flexlight 1010-1500
<b>101013</b> Keller Art. Nr. 600004004	Flexlight 1510-2000 Flexlight 1510-2000 Flexlight 1510-2000



  	<p>Die Montage des Spiegels muss durch einen Fachmann im Sanitärbereich erfolgen.                  Arbeiten an den elektrischen Installationen dürfen nur von autorisierten Fachleuten nach den örtlichen Vorschriften ausgeführt werden.                  Für nicht fachgerechte Installation wird jegliche Haftung Abgelehnt.</p>
  	<p>Le montage du miroir doit être effectué par un spécialiste autorisé en équipement sanitaire.                  Les travaux à l'installation électrique ne doivent pas être effectués que par des spécialistes autorisés selon les prescriptions locales.                  Si l'installation n'est pas faites par un expert nous déclinons toute responsabilité.</p>
  	<p>Il montaggio dello specchio deve essere eseguito da personale autorizzato del settore impianti sanitari.                  L'installazione elettrica deve essere eseguita da personale autorizzato secondo le norme vigenti del posto. Se l'installazione non viene eseguita dal personale autorizzato decliniamo ogni responsabilità.</p>

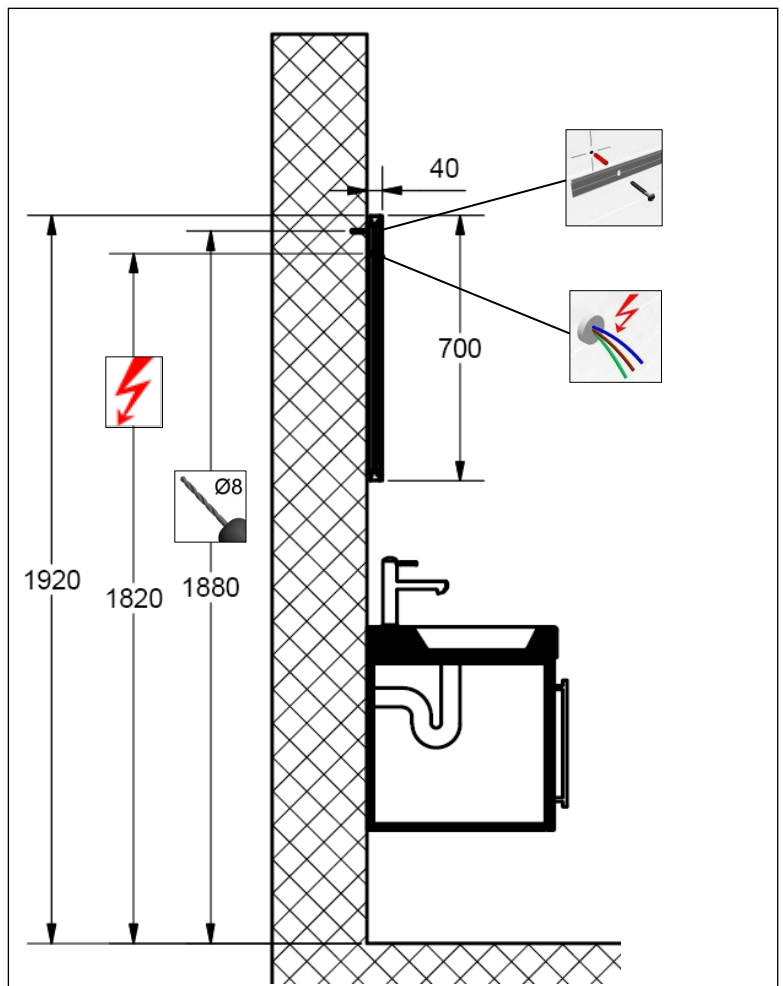
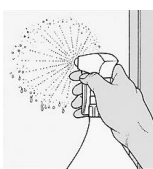

	<p>Achtung: Pflegehinweise beachten.                  Attention: observez les conseils d'entretien.                  Attenzione: osservare le istruzioni di pulizia.</p>
---	--

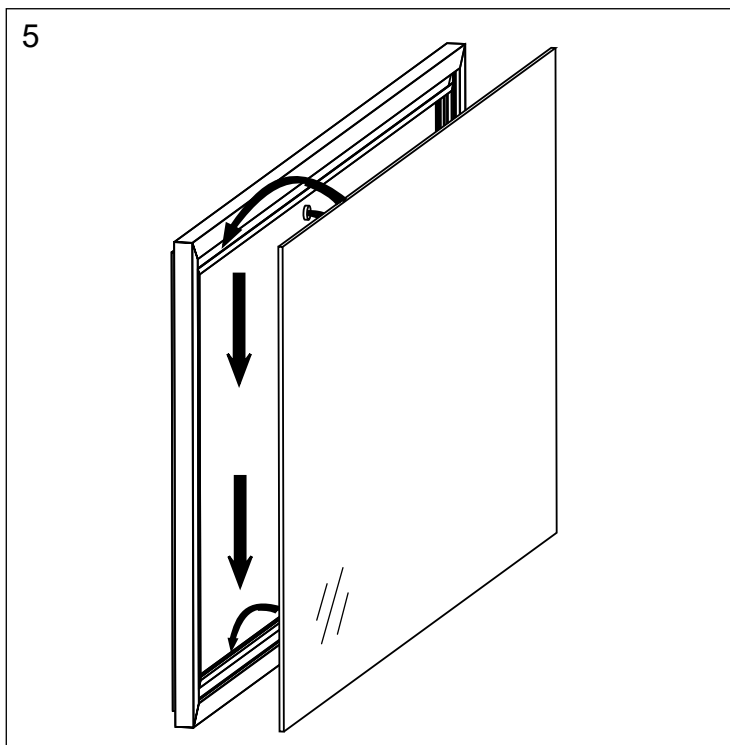
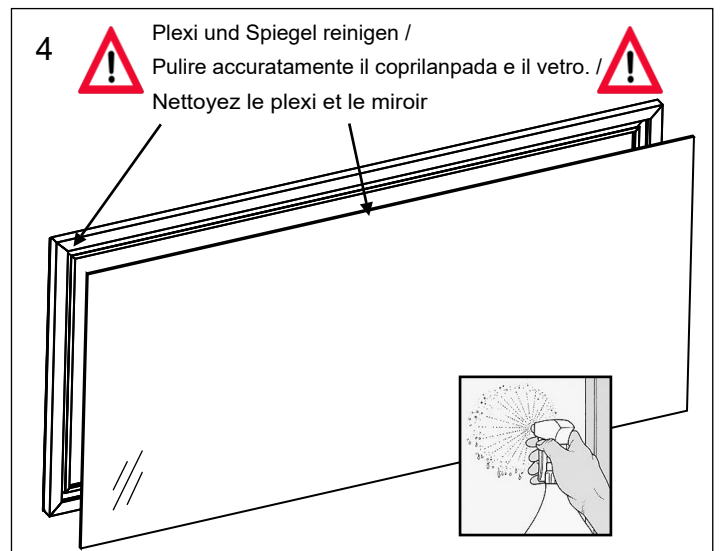
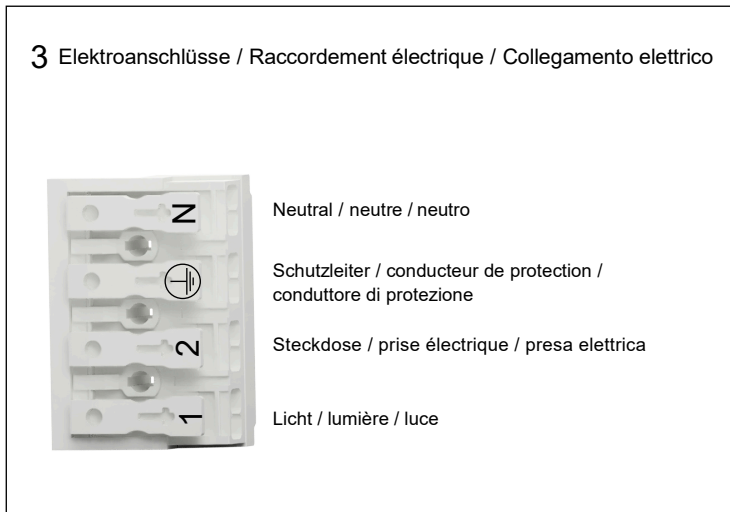
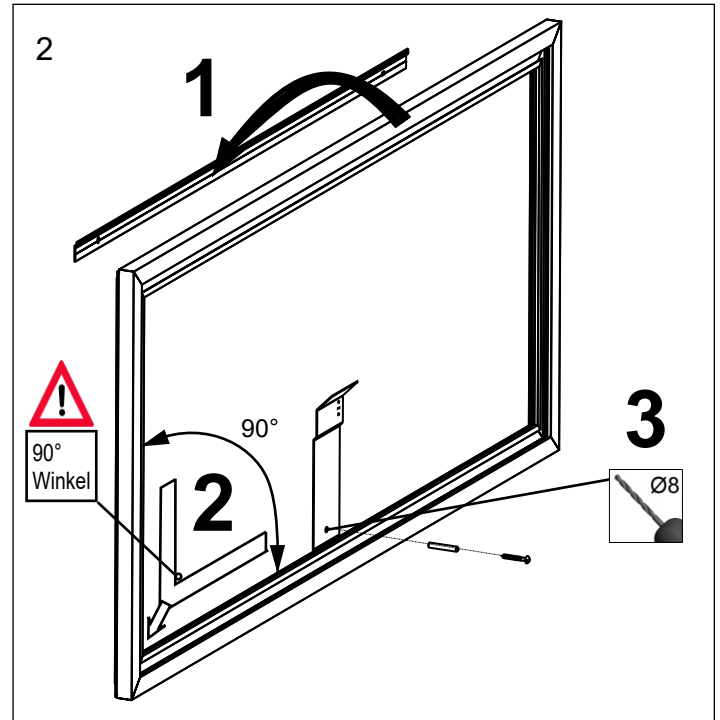
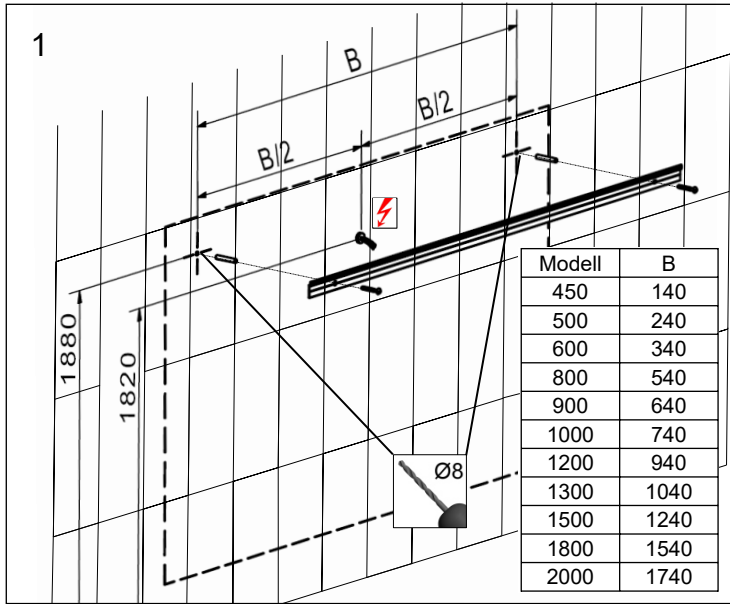

Alle Masse sind in mm angegeben. / Toutes les mesures sont indiquées en mm. / Tutte le misure sono indicate in mm.