

Massskizze / Montageanleitung Duplex

Fiche de mesure / Instruction de montage Duplex
 Scheda misure / Istruzione di montaggio Duplex

Keller

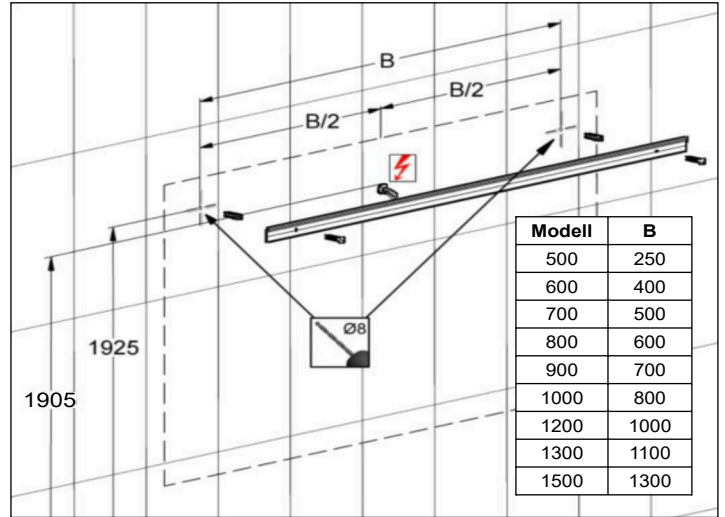
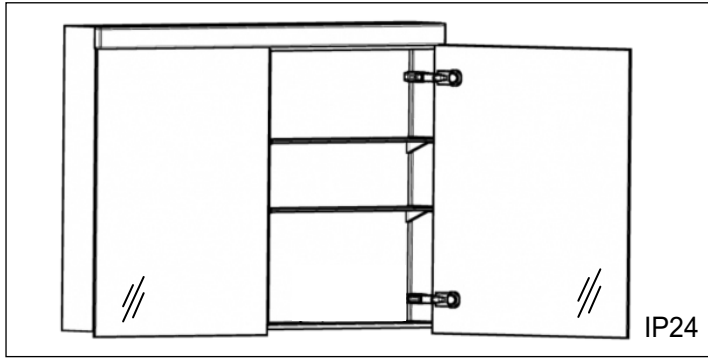

102076 Keller Art. Nr. 319303173	Duplex 500/1T/BL Duplex 500/1P/CG Duplex 500/1P/CS
102077 Keller Art. Nr. 319303183	Duplex 500/1T/BR Duplex 500/1P/CD Duplex 500/1P/CD
102071 Keller Art. Nr. 319303013	Duplex 600/1T/BL Duplex 600/1P/CG Duplex 600/1P/CS
102072 Keller Art. Nr. 319303023	Duplex 600/1T/BR Duplex 600/1P/CD Duplex 600/1P/CD
102073 Keller Art. Nr. 319303053	Duplex 600/2T/STR Duplex 600/2P/PCD Duplex 600/2P/PCD
102695 Keller Art. Nr. 319303054	Duplex 600/2T/STL Duplex 600/2P/PCG Duplex 600/2P/PCS
102074 Keller Art. Nr. 319303063	Duplex 700/2T/STR Duplex 700/2P/PCD Duplex 700/2P/PCD
102696 Keller Art. Nr. 319303064	Duplex 700/2T/STL Duplex 700/2P/PCG Duplex 700/2P/PCS
102075 Keller Art. Nr. 319303073	Duplex 800/2T Duplex 800/2P Duplex 800/2P
102078 Keller Art. Nr. 319303313	Duplex 900/45/45/2T Duplex 900/45/45/2P Duplex 900/45/45/2P
102079 Keller Art. Nr. 319303333	Duplex 900/60/30/2T Duplex 900/60/30/2P Duplex 900/60/30/2P

102080 Keller Art. Nr. 319303343	Duplex 900/30/60/2T Duplex 900/30/60/2P Duplex 900/30/60/2P
102081 Keller Art. Nr. 319303413	Duplex 1000/2T Duplex 1000/2P Duplex 1000/2P
102082 Keller Art. Nr. 319303423	Duplex 1000/3T Duplex 1000/3P Duplex 1000/3P
102083 Keller Art. Nr. 319303513	Duplex 1200/2T Duplex 1200/2P Duplex 1200/2P
102084 Keller Art. Nr. 319303523	Duplex 1200/3T Duplex 1200/3P Duplex 1200/3P
102086 Keller Art. Nr. 319303733	Duplex 1300/2T Duplex 1300/2P Duplex 1300/2P
102085 Keller Art. Nr. 319303723	Duplex 1300/3T Duplex 1300/3P Duplex 1300/3P
102087 Keller Art. Nr. 319303813	Duplex 1500/3T Duplex 1500/3P Duplex 1500/3P

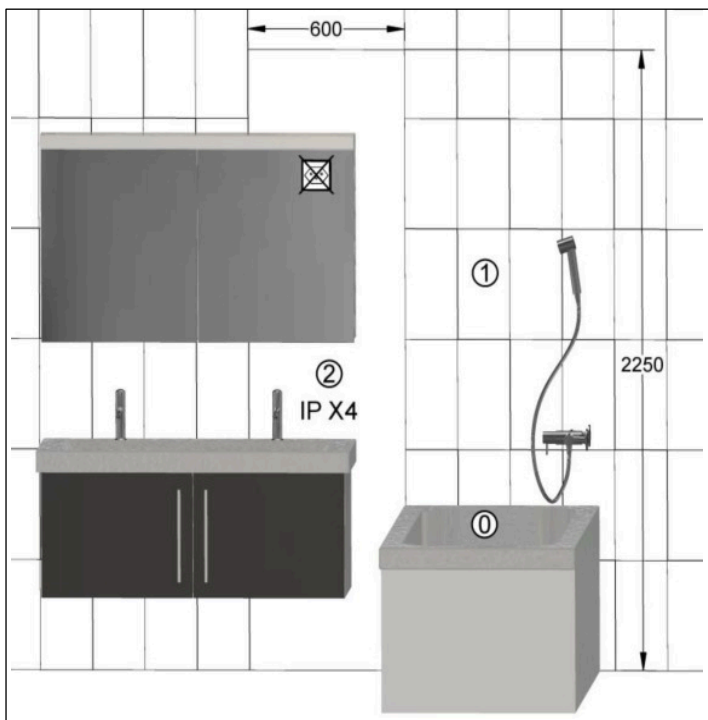
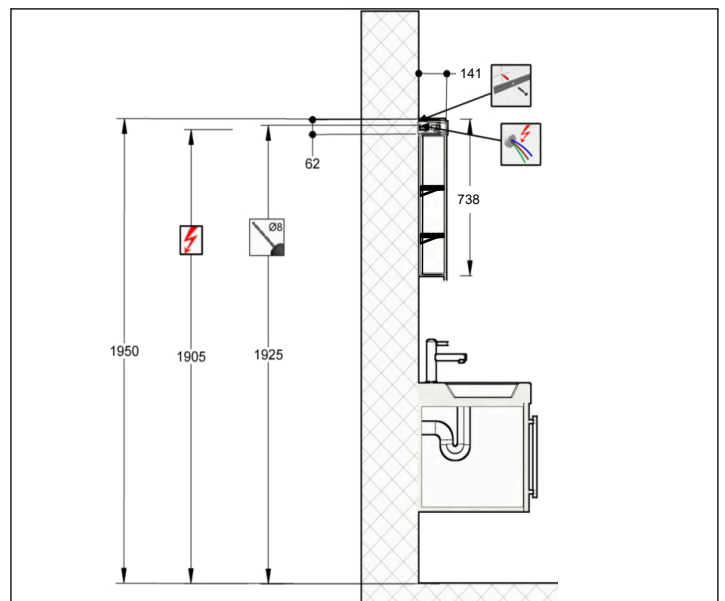

- Die Montage des Spiegelschranks muss durch einen Fachmann im Sanitärbereich erfolgen.
- Arbeiten an den elektrischen Installationen dürfen nur von autorisierten Fachleuten nach den örtlichen Vorschriften ausgeführt werden. Für nicht fachgerechte Installation wird jegliche Haftung abgelehnt.
- Räume mit Badewanne ① oder mit Dusche ① müssen mit einer FI-Schutzeinrichtung (RCD) I $\Delta n = 30\text{mA}$ gesichert sein. Bereich ② mindestens Schutzart IP X4. Bereich ② keine Steckdosen.
- Le montage de l'armoire de toilette doit être effectué par un spécialiste autorisé en équipement sanitaire.
- Les travaux à l'installation électrique ne doivent pas être effectués que par des spécialistes autorisés selon les prescriptions locales. Si l'installation n'est pas faite par un expert nous déclinons toute responsabilité.
- Locaux avec baignoire ① ou douche ① doivent être protégés par un dispositif de protection FI (RCD) I $\Delta n = 30\text{mA}$. Volume ② mind. degré de protection IP X4. Volume ② des prises électriques ne sont pas permises.
- Il montaggio dell'armadietto da bagno deve essere eseguito da personale autorizzato del settore impianti sanitari.
- L'installazione elettrica deve essere eseguita da personale autorizzato secondo le norme vigenti del posto. Se l'installazione non viene eseguita dal personale autorizzato decliniamo ogni responsabilità.
- Ambienti con vasca da bagno ① o doccia ① devono essere protetti con un dispositivo di protezione FI (RCD) I $\Delta n = 30\text{mA}$. Zona ② come minimo sistema di protezione IP X4. Zona ② non sono autorizzate le prese di corrente.

Massskizze / Montageanleitung Duplex

Fiche de mesure / Instruction de montage Duplex

Scheda misure / Istruzione di montaggio Duplex

Keller

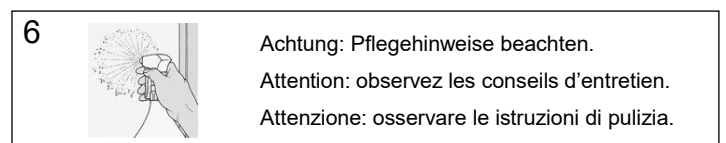
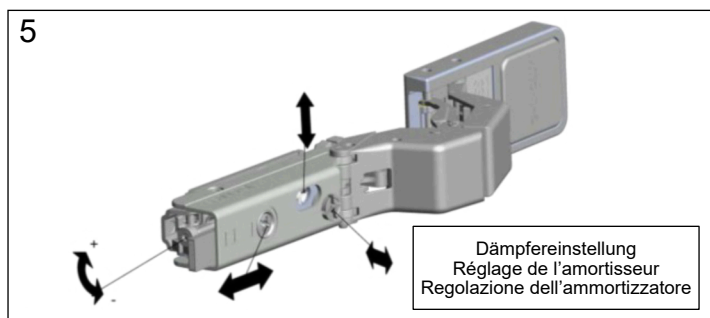
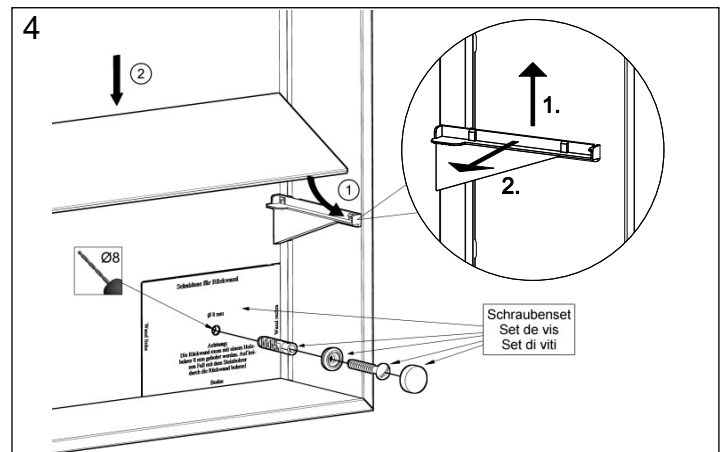
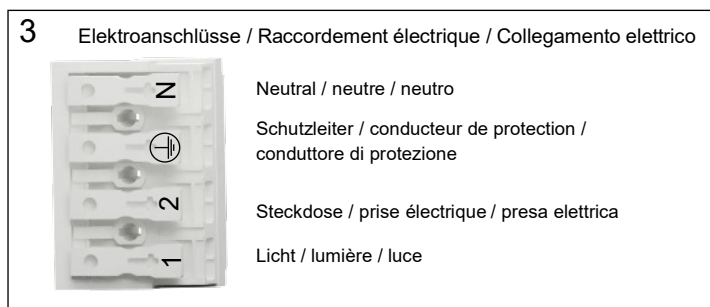
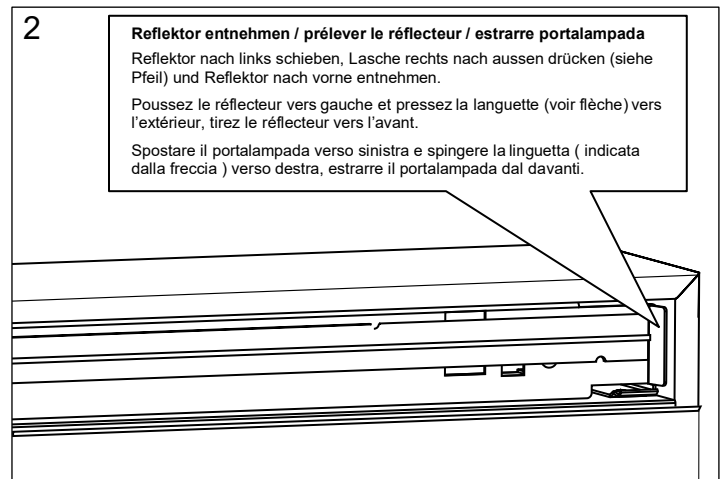
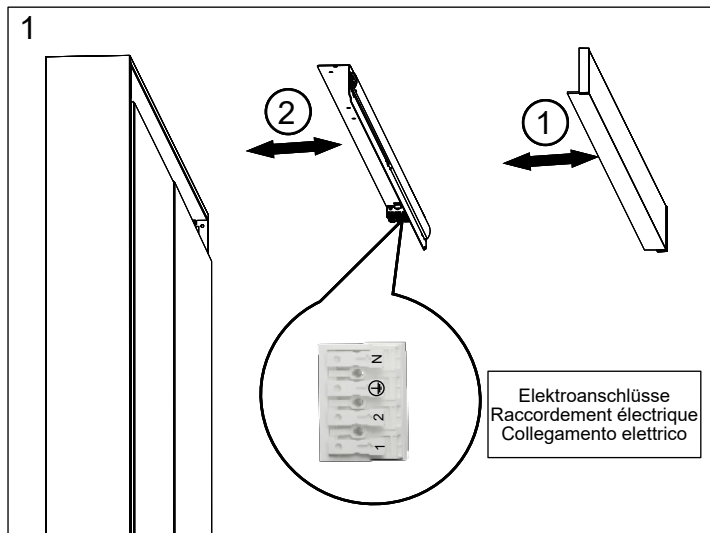
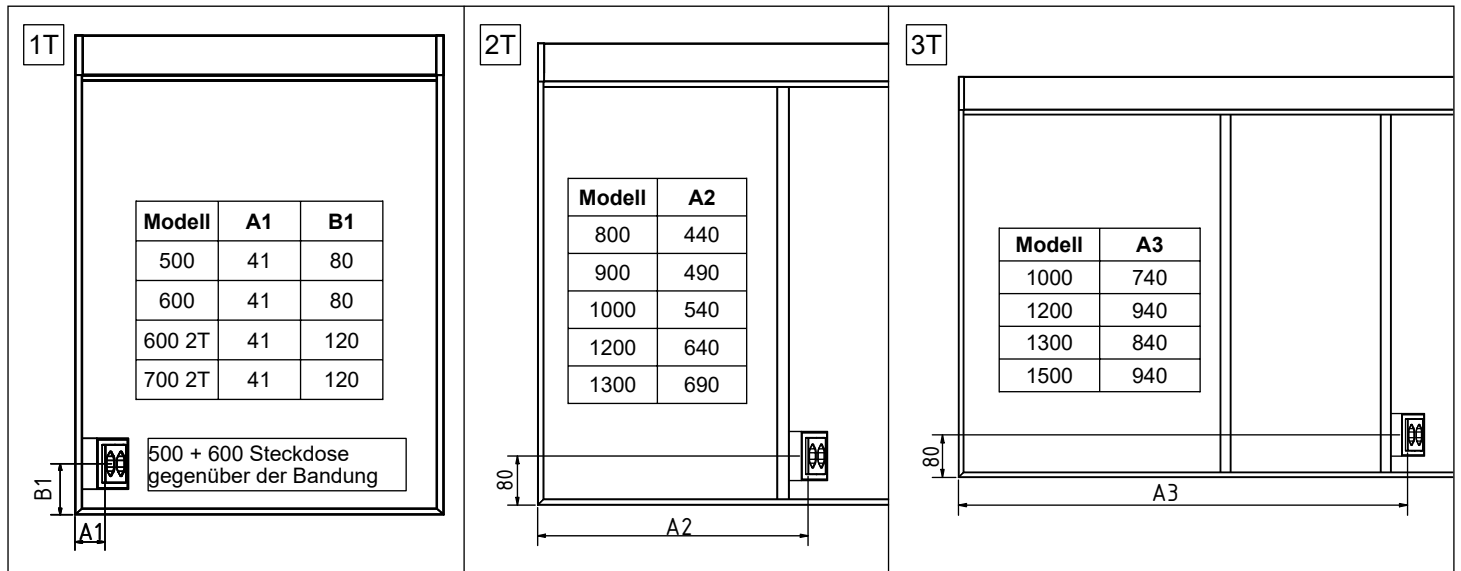

Alle Masse sind in mm angegeben. / Toutes les mesures sont indiquées en mm. / Tutte le misure sono indicate in mm.

Massskizze / Montageanleitung Wandeinbau Duplex

Fiche de mesure / Instruction de montage pour l'encastrement Duplex
 Scheda misura / Istruzione di montaggio ad incasso Duplex

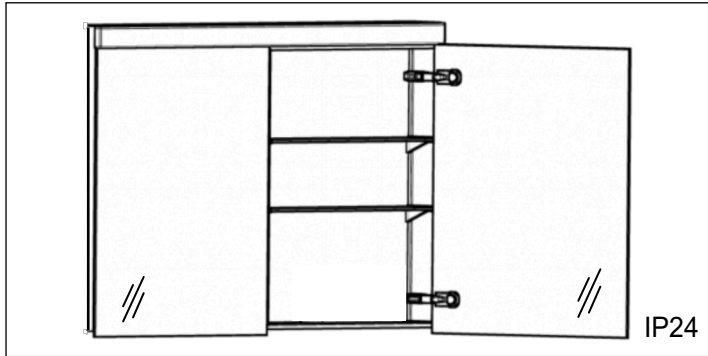

102076 Keller Art. Nr. 319303173	Duplex 500/1T/BL Duplex 500/1P/CG Duplex 500/1P/CS
102077 Keller Art. Nr. 319303183	Duplex 500/1T/BR Duplex 500/1P/CD Duplex 500/1P/CD
102071 Keller Art. Nr. 319303013	Duplex 600/1T/BL Duplex 600/1P/CG Duplex 600/1P/CS
102072 Keller Art. Nr. 319303023	Duplex 600/1T/BR Duplex 600/1P/CD Duplex 600/1P/CD
102073 Keller Art. Nr. 319303053	Duplex 600/2T/STR Duplex 600/2P/PCD Duplex 600/2P/PCD
102695 Keller Art. Nr. 319303054	Duplex 600/2T/STL Duplex 600/2P/PCG Duplex 600/2P/PCS
102074 Keller Art. Nr. 319303063	Duplex 700/2T/STR Duplex 700/2P/PCD Duplex 700/2P/PCD
102696 Keller Art. Nr. 319303064	Duplex 700/2T/STL Duplex 700/2P/PCG Duplex 700/2P/PCS
102075 Keller Art. Nr. 319303073	Duplex 800/2T Duplex 800/2P Duplex 800/2P
102078 Keller Art. Nr. 319303313	Duplex 900/45/45/2T Duplex 900/45/45/2P Duplex 900/45/45/2P
102079 Keller Art. Nr. 319303333	Duplex 900/60/30/2T Duplex 900/60/30/2P Duplex 900/60/30/2P

102080 Keller Art. Nr. 319303343	Duplex 900/30/60/2T Duplex 900/30/60/2P Duplex 900/30/60/2P
102081 Keller Art. Nr. 319303413	Duplex 1000/2T Duplex 1000/2P Duplex 1000/2P
102082 Keller Art. Nr. 319303423	Duplex 1000/3T Duplex 1000/3P Duplex 1000/3P
102083 Keller Art. Nr. 319303513	Duplex 1200/2T Duplex 1200/2P Duplex 1200/2P
102084 Keller Art. Nr. 319303523	Duplex 1200/3T Duplex 1200/3P Duplex 1200/3P
102086 Keller Art. Nr. 319303733	Duplex 1300/2T Duplex 1300/2P Duplex 1300/2P
102085 Keller Art. Nr. 319303723	Duplex 1300/3T Duplex 1300/3P Duplex 1300/3P
102087 Keller Art. Nr. 319303813	Duplex 1500/3T Duplex 1500/3P Duplex 1500/3P

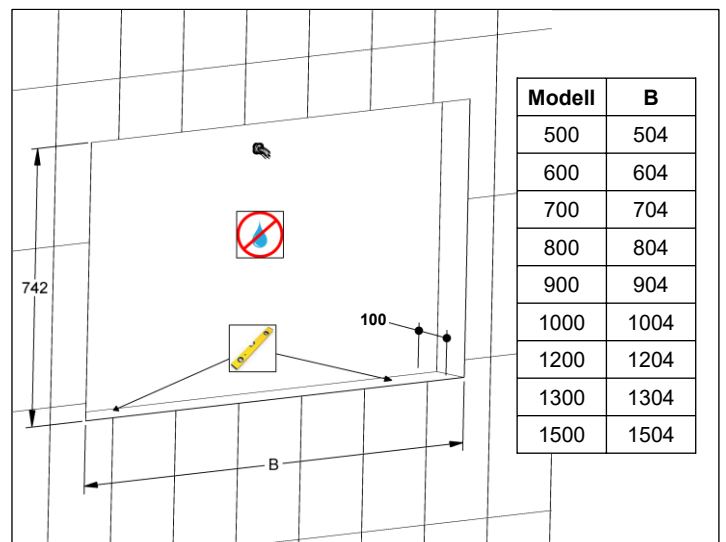
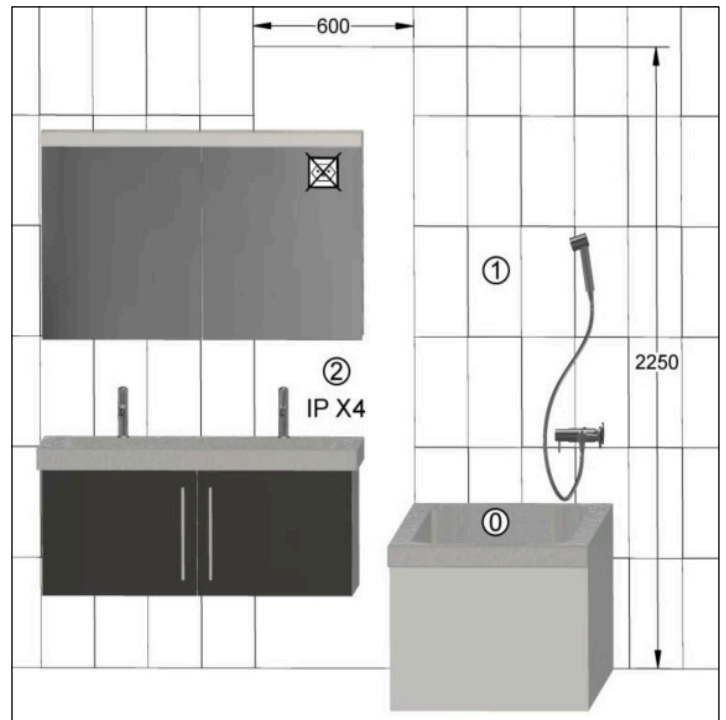
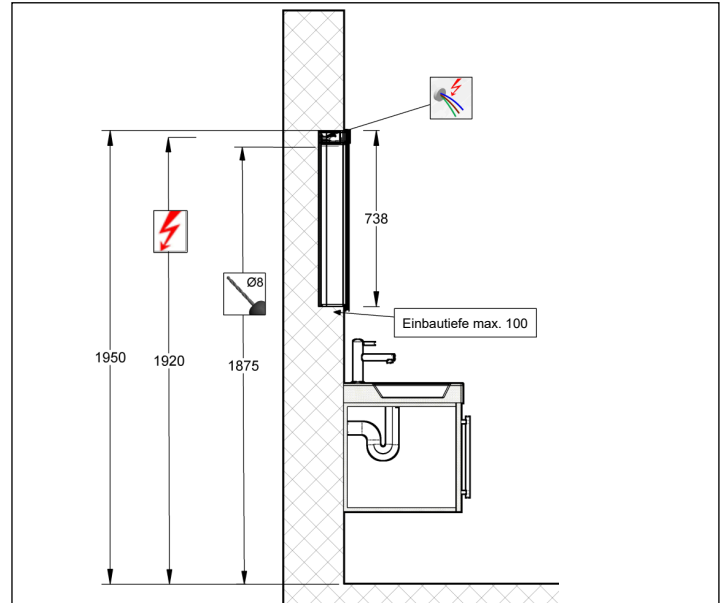

- Die Montage des Spiegelschranks muss durch einen Fachmann im Sanitärbereich erfolgen.
- Arbeiten an den elektrischen Installationen dürfen nur von autorisierten Fachleuten nach den örtlichen Vorschriften ausgeführt werden. Für nicht fachgerechte Installation wird jegliche Haftung abgelehnt.
- Räume mit Badewanne ① oder mit Dusche ① müssen mit einer FI-Schutteinrichtung (RCD) I $\Delta n = 30\text{mA}$ gesichert sein. Bereich ② mindestens Schutzart IP X4. Bereich ② keine Steckdosen.
- Le montage de l'armoire de toilette doit être effectué par un spécialiste autorisé en équipement sanitaire.
- Les travaux à l'installation électrique ne doivent pas être effectués que par des spécialistes autorisés selon les prescriptions locales. Si l'installation n'est pas faite par un expert nous déclinons toute responsabilité.
- Locaux avec baignoire ① ou douche ① doivent être protégés par un dispositif de protection FI (RCD) I $\Delta n = 30\text{mA}$. Volume ② mind. degré de protection IP X4. Volume ② des prises électriques ne sont pas permises.
- Il montaggio dell'armadietto da bagno deve essere eseguito da personale autorizzato del settore impianti sanitari.
- L'installazione elettrica deve essere eseguita da personale autorizzato secondo le norme vigenti del posto. Se l'installazione non viene eseguita dal personale autorizzato decliniamo ogni responsabilità.
- Ambienti con vasca da bagno ① o doccia ① devono essere protetti con un dispositivo di protezione FI (RCD) I $\Delta n = 30\text{mA}$. Zona ② come minimo sistema di protezione IP X4. Zona ② non sono autorizzate le prese di corrente.

Massskizze / Montageanleitung Wandeinbau Duplex

Fiche de mesure / Instruction de montage pour l'encastrement Duplex
 Scheda misura / Istruzione di montaggio ad incasso Duplex

Keller

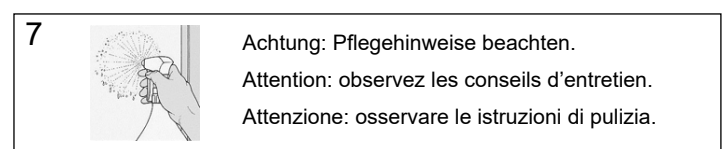
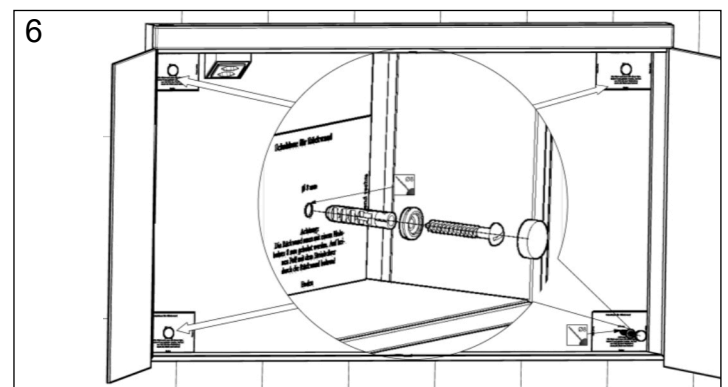
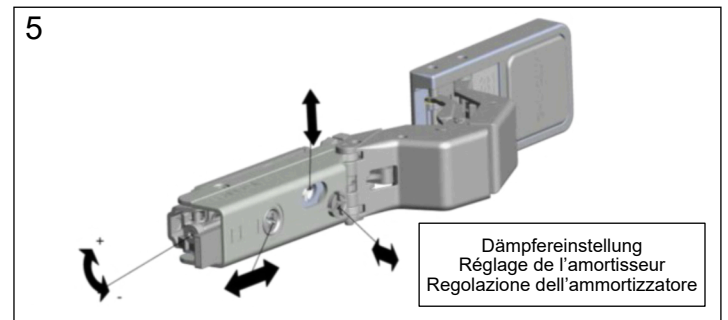
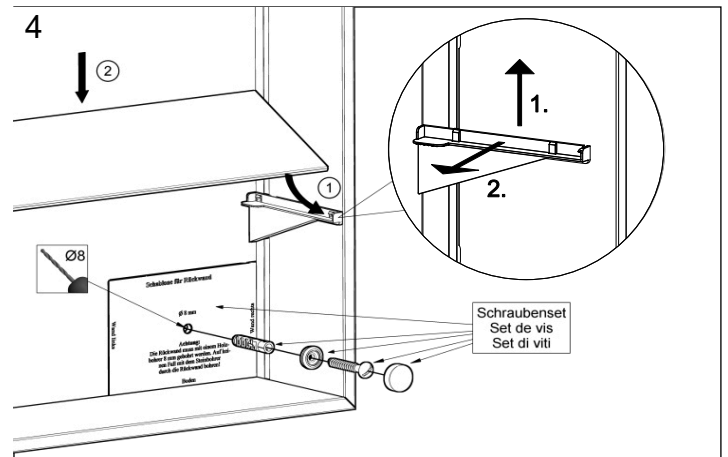
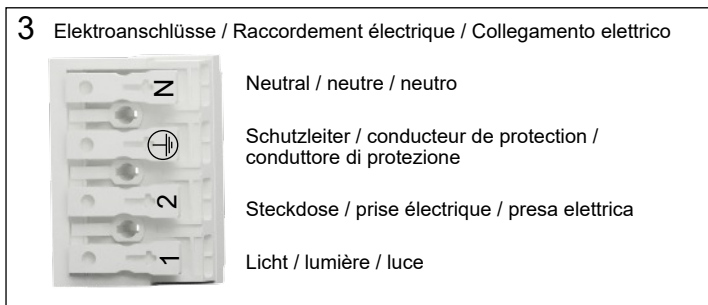
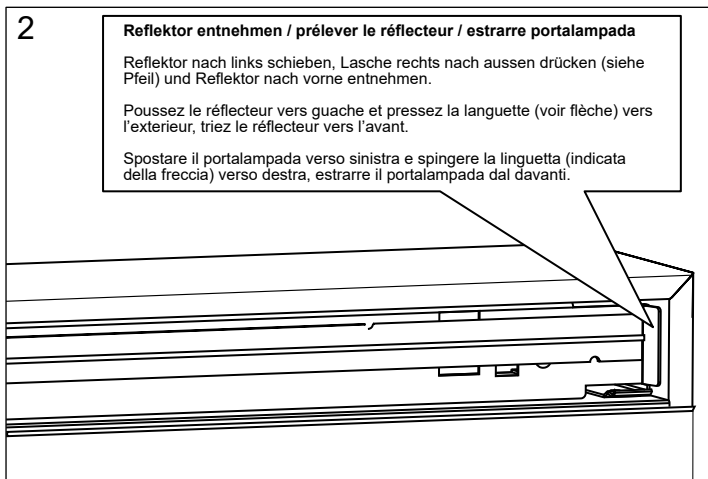
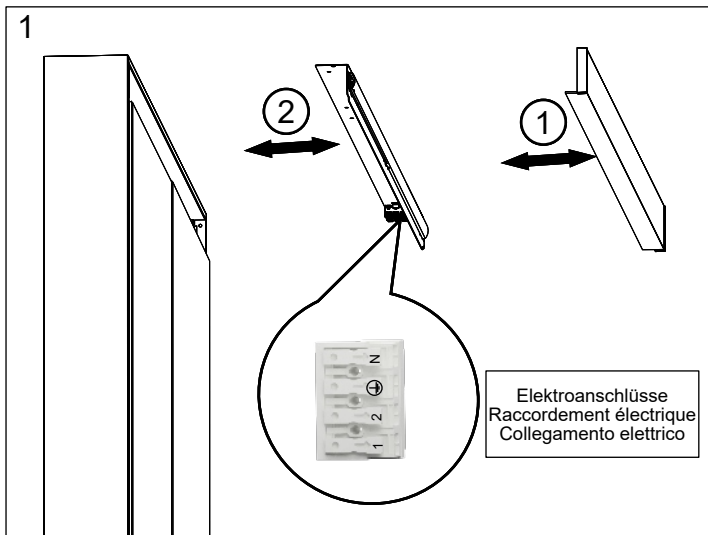
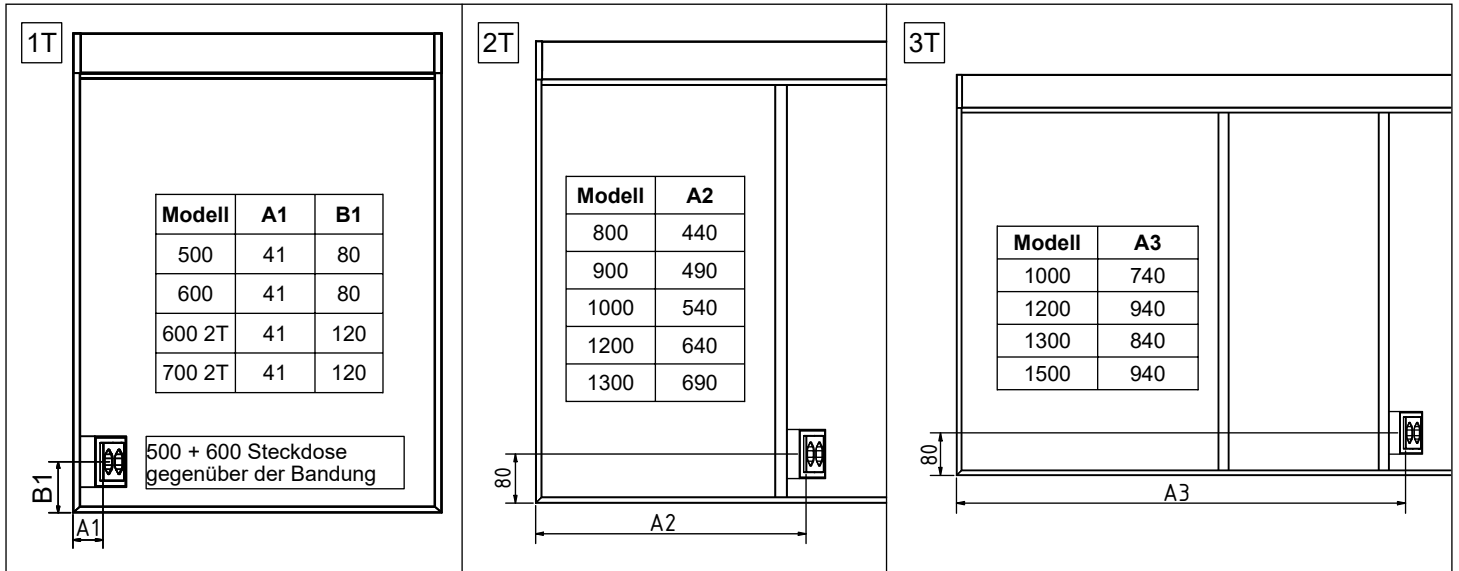

Alle Masse sind in mm angegeben. / Toutes les mesures sont indiquées en mm. / Tutte le misure sono indicate in mm.