

Massskizze / Montageanleitung Puro 2.0

Fiche de mesure / Instruction de montage Puro 2.0

Scheda misure / Istruzione di montaggio Puro 2.0

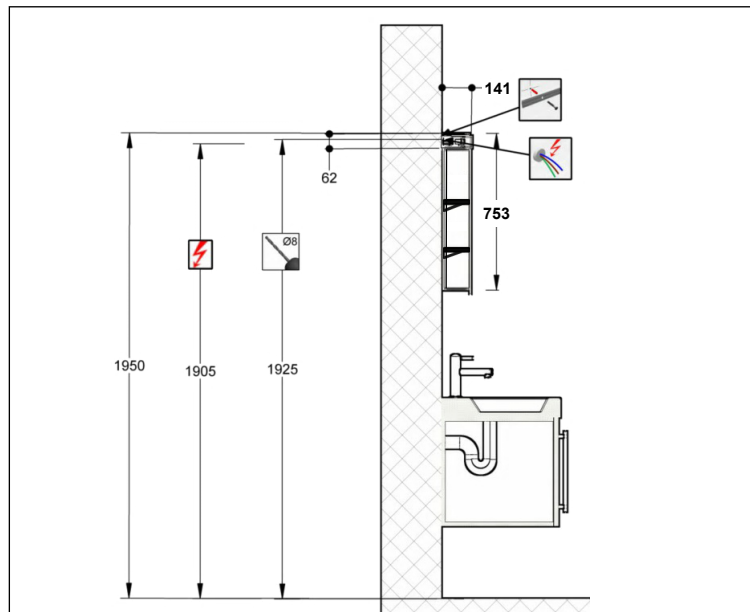
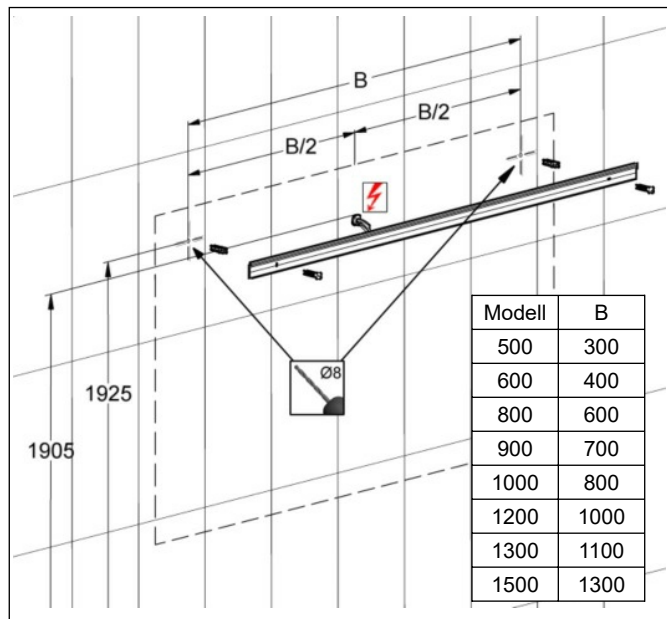
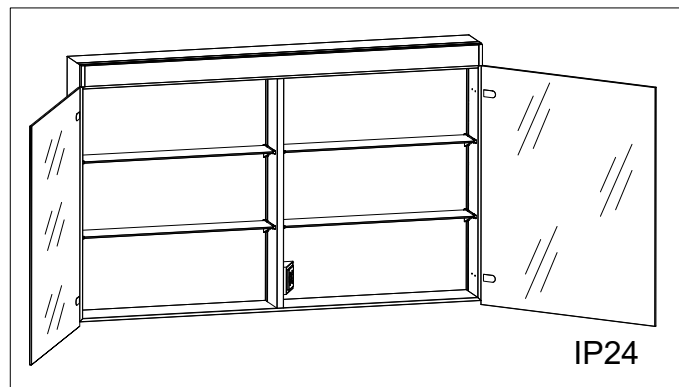

614538 Keller Art. Nr. 317003173	Puro 2.0 500/1T/BL Puro 2.0 500/1P/CG Puro 2.0 500/1P/CS
614539 Keller Art. Nr. 317003183	Puro 2.0 500/1T/BR Puro 2.0 500/1P/CD Puro 2.0 500/1P/CS
614540 Keller Art. Nr. 317003013	Puro 2.0 600/1T/BL Puro 2.0 600/1P/CG Puro 2.0 600/1P/CS
614541 Keller Art. Nr. 317003023	Puro 2.0 600/1T/BR Puro 2.0 600/1P/CD Puro 2.0 600/1P/CS
614542 Keller Art. Nr. 317003073	Puro 2.0 800/2T Puro 2.0 800/2P Puro 2.0 800/2P
614543 Keller Art. Nr. 317003313	Puro 2.0 900/2T Puro 2.0 900/2P Puro 2.0 900/2P

614544 Keller Art. Nr. 317003413	Puro 2.0 1000/2T Puro 2.0 1000/2P Puro 2.0 1000/2P
614545 Keller Art. Nr. 317003513	Puro 2.0 1200/2T Puro 2.0 1200/2P Puro 2.0 1200/2P
614547 Keller Art. Nr. 317003733	Puro 2.0 1300/2T Puro 2.0 1300/2P Puro 2.0 1300/2P
614546 Keller Art. Nr. 317003723	Puro 2.0 1300/3T Puro 2.0 1300/3T Puro 2.0 1300/3T
614548 Keller Art. Nr. 317003813	Puro 2.0 1500/3T Puro 2.0 1500/3T Puro 2.0 1500/3T













Die Montage des Spiegelschranks muss durch einen Fachmann im Sanitärbereich erfolgen. Arbeiten an den elektrischen Installationen dürfen nur von autorisierten Fachleuten nach den örtlichen Vorschriften ausgeführt werden. Für nicht fachgerechte Installation wird jegliche Haftung abgelehnt. Räume mit Badewanne ① oder Dusche ② müssen mit einer FI-Schutzeinrichtung (RCD) I Δ n = 30mA gesichert sein. Bereich ② mindestens Schutzart IP X4. Bereich ② keine Steckdosen.

Le montage de l'armoire de toilette doit être effectué par un spécialiste autorisé en équipement sanitaire. Les travaux à l'installation électrique ne doivent pas être effectués que par des spécialistes autorisés selon les prescriptions locales. Si l'installation n'est pas faite par un expert nous déclinons toute responsabilité. Locaux avec baignoire ① ou douche ② doivent être protégés par un dispositif de protection FI (RCD) I Δ n = 30mA. Volume ② mind. degré de protection IP X4. Volume ② des prises électriques ne sont pas permises.

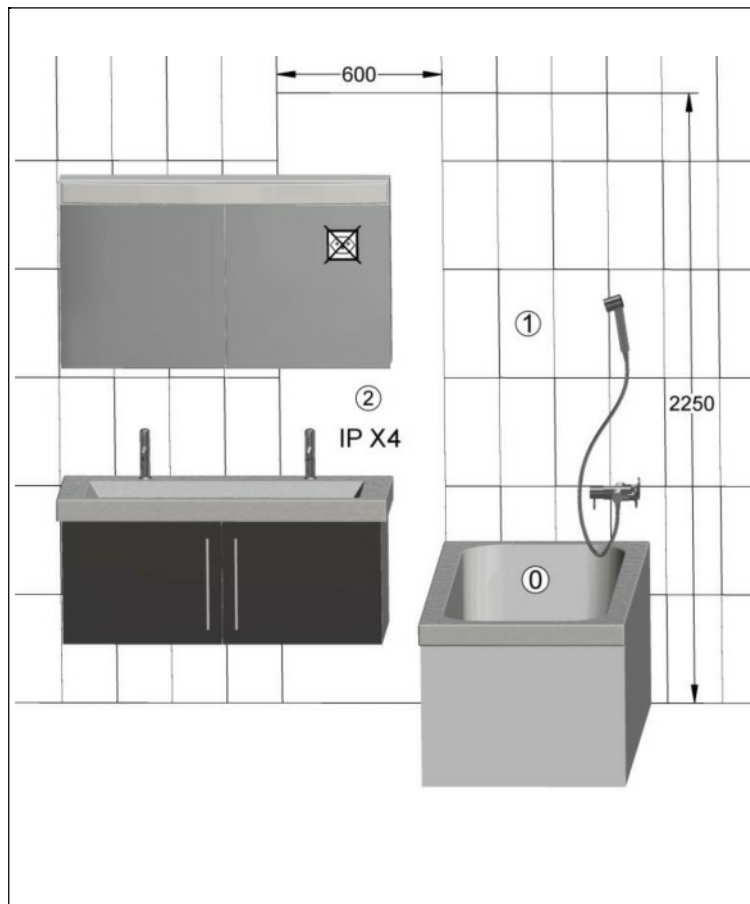
Il montaggio dell'armadietto da bagno deve essere eseguito da personale autorizzato del settore impianti sanitari. L'installazione elettrica deve essere eseguita da personale autorizzato secondo le norme vigenti del posto. Se l'installazione non viene eseguita dal personale autorizzato decliniamo ogni responsabilità. Ambienti con vasca da bagno ① o doccia ② devono essere protetti con un dispositivo di protezione FI (RCD) I Δ n = 30mA. Zona ② come minimo sistema di protezione IP X4. Zona ② non sono autorizzate le prese di corrente.



Alle Masse sind in mm angegeben. / Toutes les mesures sont indiquées en mm. / Tutte le misure sono indicate in mm.

Massskizze / Montageanleitung Puro 2.0

Fiche de mesure / Instruction de montage Puro 2.0

Scheda misure / Istruzione di montaggio Puro 2.0

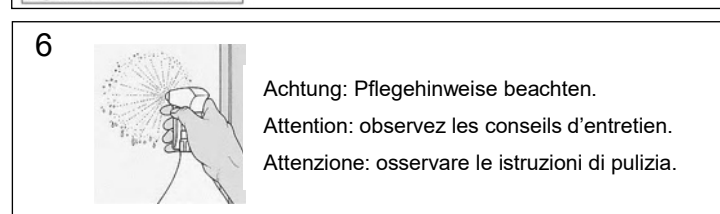
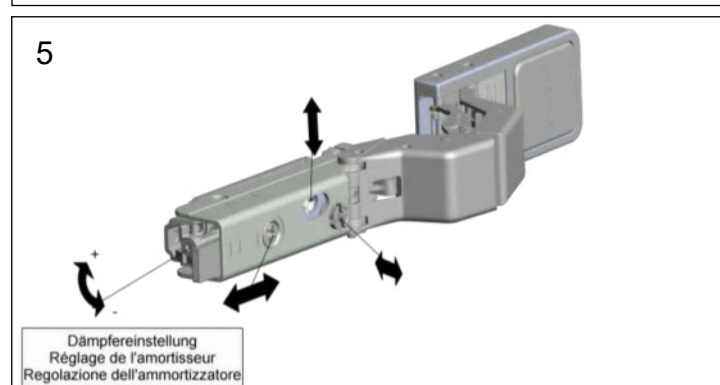
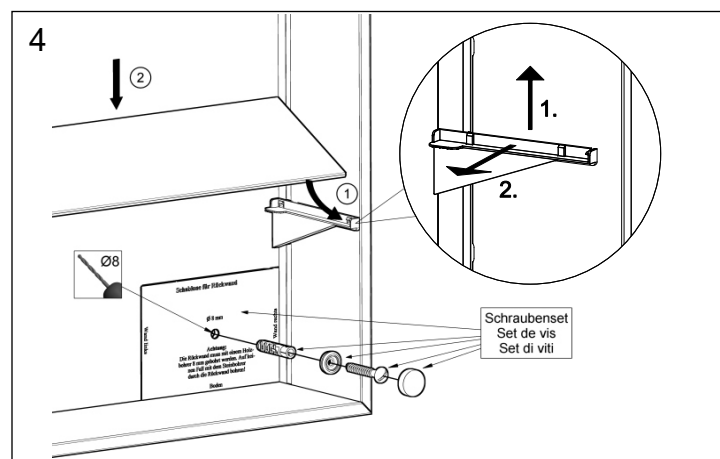
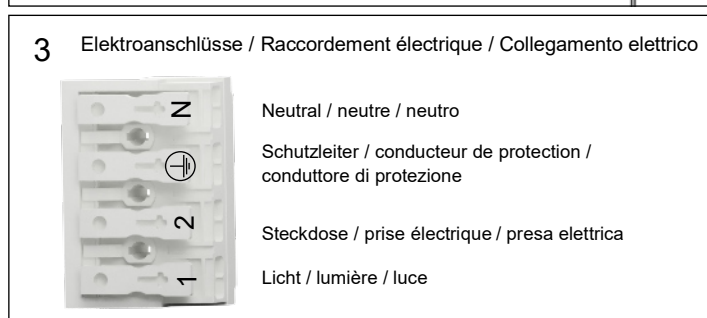
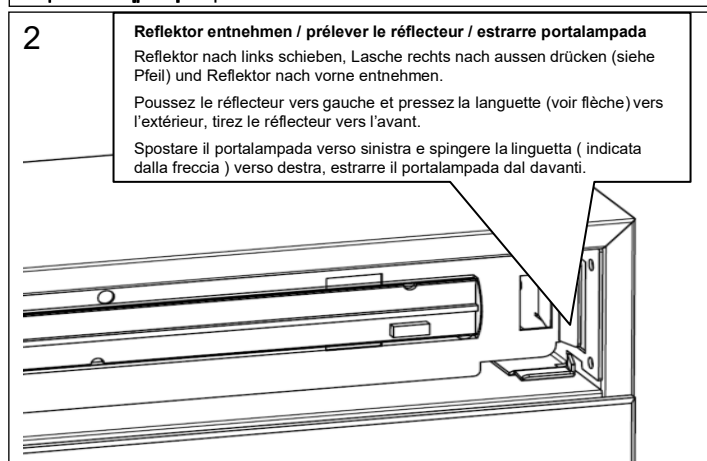
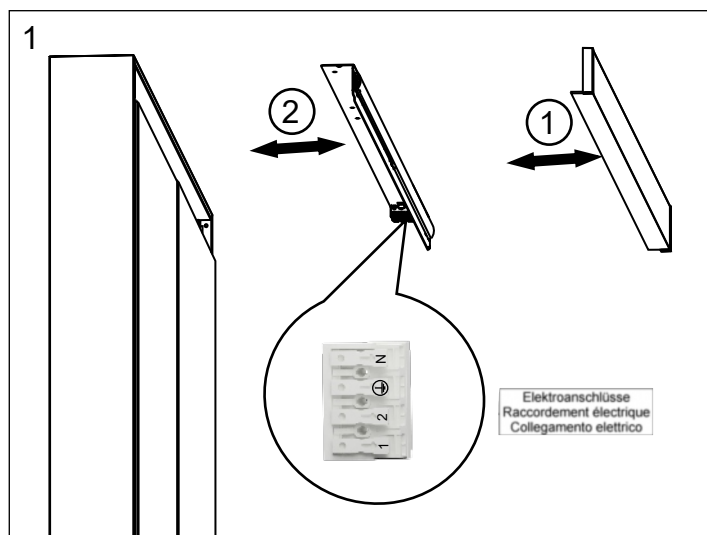
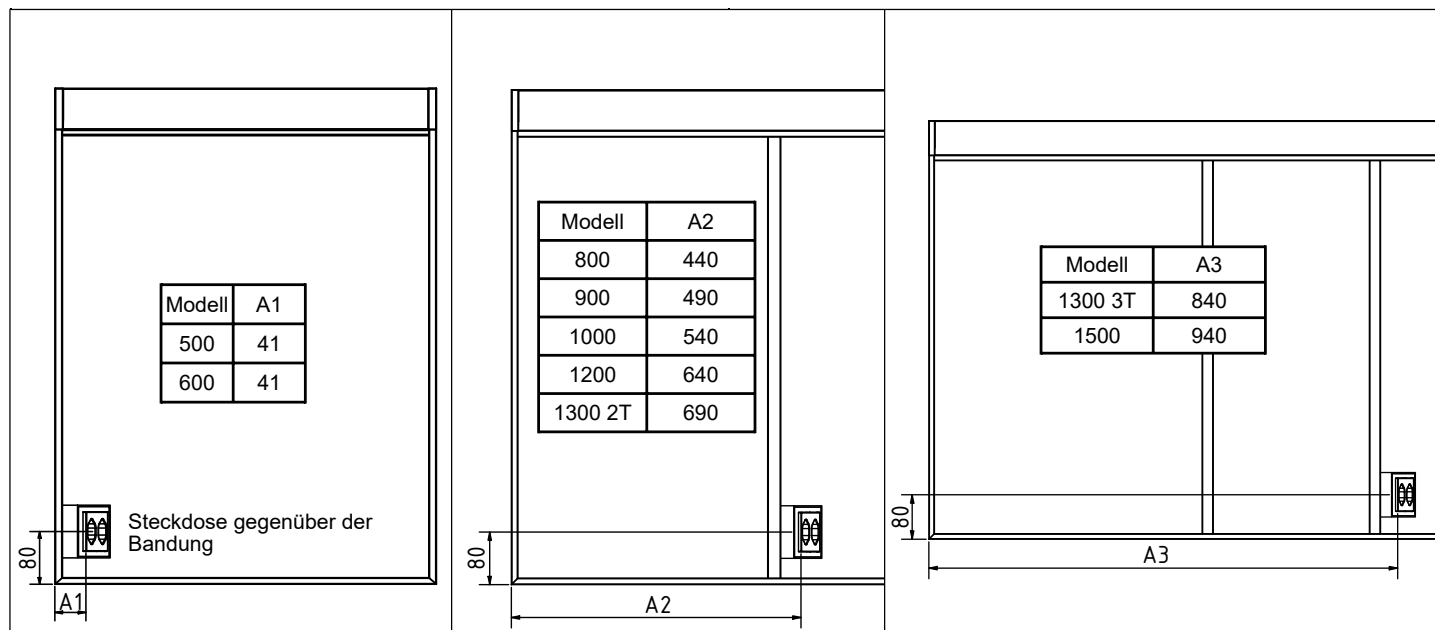

Massskizze / Montageanleitung Wandeinbau Puro 2.0

Fiche de mesure / Instruction de montage pour l'encastrement Puro 2.0

Istruzione di montaggio ad incasso Puro 2.0

614538 Keller Art. Nr. 317003173	Puro 2.0 500/1T/BL Puro 2.0 500/1P/CG Puro 2.0 500/1P/CS
614539 Keller Art. Nr. 317003183	Puro 2.0 500/1T/BR Puro 2.0 500/1P/CD Puro 2.0 500/1P/CS
614540 Keller Art. Nr. 317003013	Puro 2.0 600/1T/BL Puro 2.0 600/1P/CG Puro 2.0 600/1P/CS
614541 Keller Art. Nr. 317003023	Puro 2.0 600/1T/BR Puro 2.0 600/1P/CD Puro 2.0 600/1P/CS
614542 Keller Art. Nr. 317003073	Puro 2.0 800/2T Puro 2.0 800/2P Puro 2.0 800/2P
614543 Keller Art. Nr. 317003313	Puro 2.0 900/2T Puro 2.0 900/2P Puro 2.0 900/2P

614544 Keller Art. Nr. 317003413	Puro 2.0 1000/2T Puro 2.0 1000/2P Puro 2.0 1000/2P
614545 Keller Art. Nr. 317003513	Puro 2.0 1200/2T Puro 2.0 1200/2P Puro 2.0 1200/2P
614547 Keller Art. Nr. 317003733	Puro 2.0 1300/2T Puro 2.0 1300/2P Puro 2.0 1300/2P
614546 Keller Art. Nr. 317003723	Puro 2.0 1300/3T Puro 2.0 1300/3T Puro 2.0 1300/3T
614548 Keller Art. Nr. 317003813	Puro 2.0 1500/3T Puro 2.0 1500/3T Puro 2.0 1500/3T

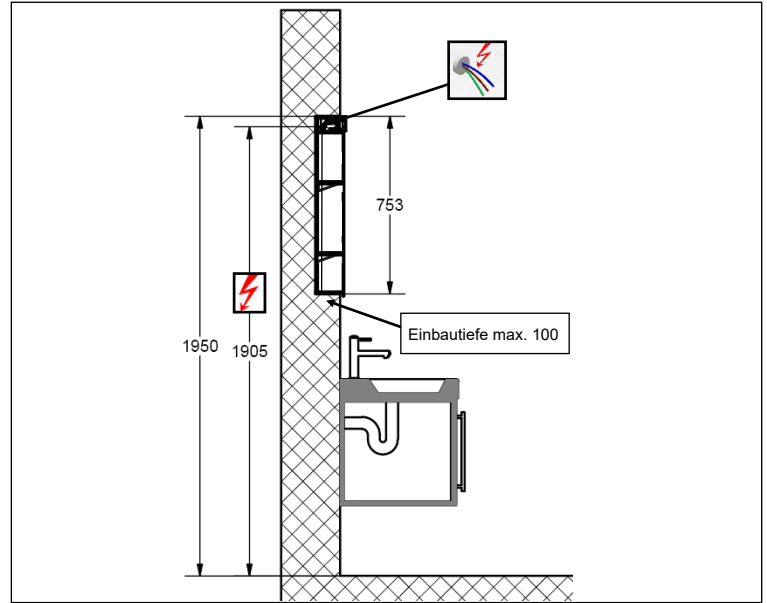
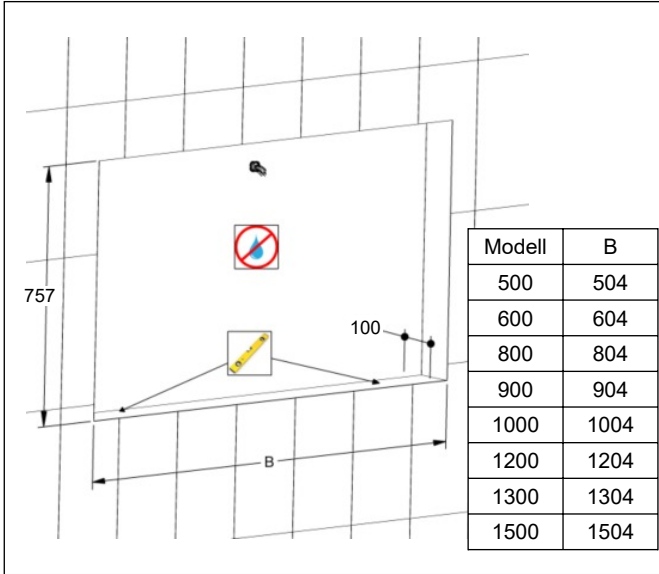
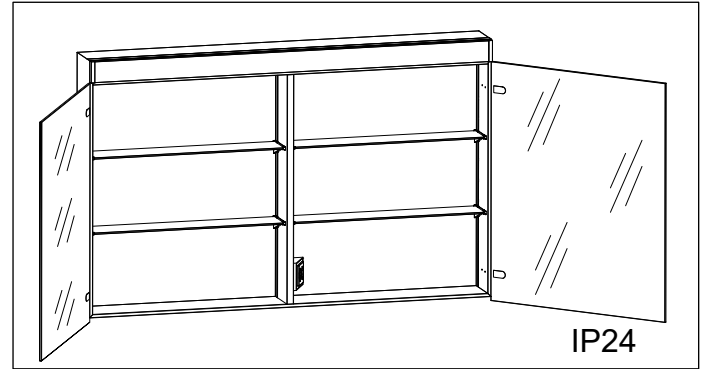











Die Montage des Spiegelschranks muss durch einen Fachmann im Sanitärbereich erfolgen. Arbeiten an den elektrischen Installationen dürfen nur von autorisierten Fachleuten nach den örtlichen Vorschriften ausgeführt werden. Für nicht fachgerechte Installation wird jegliche Haftung abgelehnt. Räume mit Badewanne ① oder Dusche ① müssen mit einer FI-Schutzeinrichtung (RCD) I Δ n = 30mA gesichert sein. Bereich ② mindestens Schutzart IP X4. Bereich ② keine Steckdosen.

Le montage de l'armoire de toilette doit être effectué par un spécialiste autorisé en équipement sanitaire. Les travaux à l'installation électrique ne doivent pas être effectués que par des spécialistes autorisés selon les prescriptions locales. Si l'installation n'est pas faite par un expert nous déclinons toute responsabilité. Locaux avec baignoire ① ou douche ① doivent être protégés par un dispositif de protection FI (RCD) I Δ n = 30mA. Volume ② mind. degré de protection IP X4. Volume ② des prises électriques ne sont pas permises.

Il montaggio dell'armadietto da bagno deve essere eseguito da personale autorizzato del settore impianti sanitari. L'installazione elettrica deve essere eseguita da personale autorizzato secondo le norme vigenti del posto. Se l'installazione non viene eseguita dal personale autorizzato decliniamo ogni responsabilità. Ambienti con vasca da bagno ① o doccia ① devono essere protetti con un dispositivo di protezione FI (RCD) I Δ n = 30mA. Zona ② come minimo sistema di protezione IP X4. Zona ② non sono autorizzate le prese di corrente.

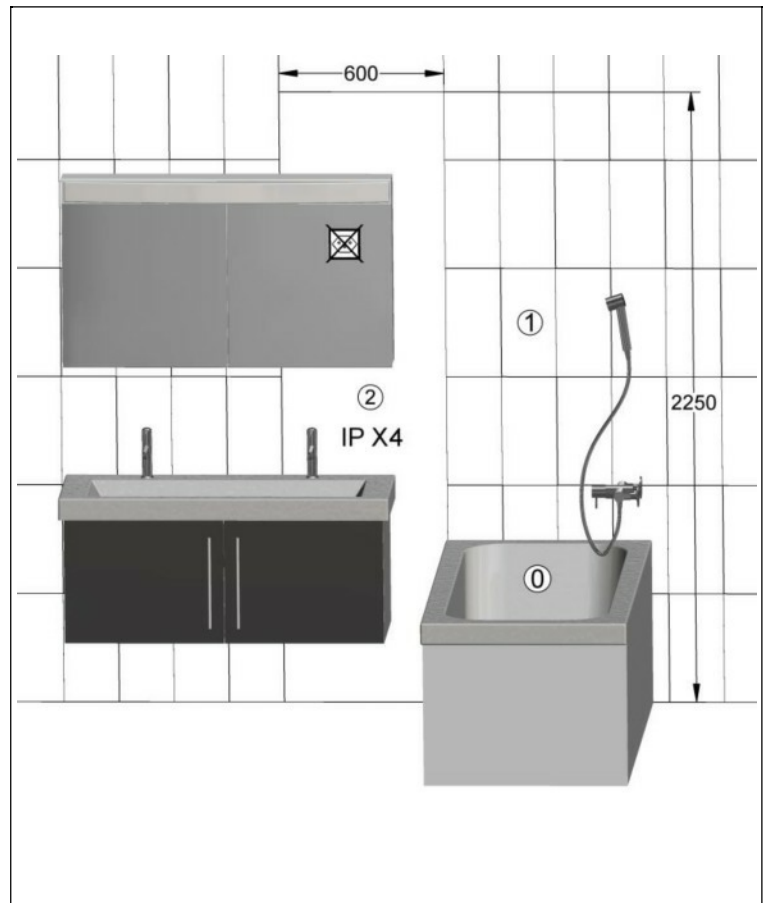

Alle Masse sind in mm angegeben. / Toutes les mesures sont indiquées en mm. / Tutte le misure sono indicate in mm.

Massskizze / Montageanleitung Wandeinbau Puro 2.0

Fiche de mesure / Instruction de montage pour l'encastrement Puro 2.0
Istruzione di montaggio ad incasso Puro 2.0

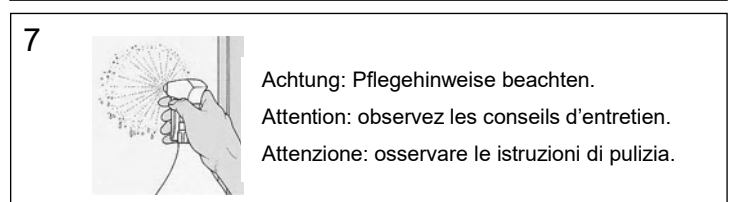
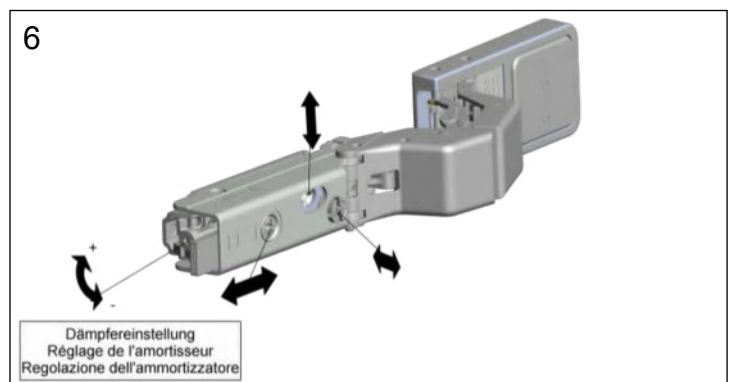
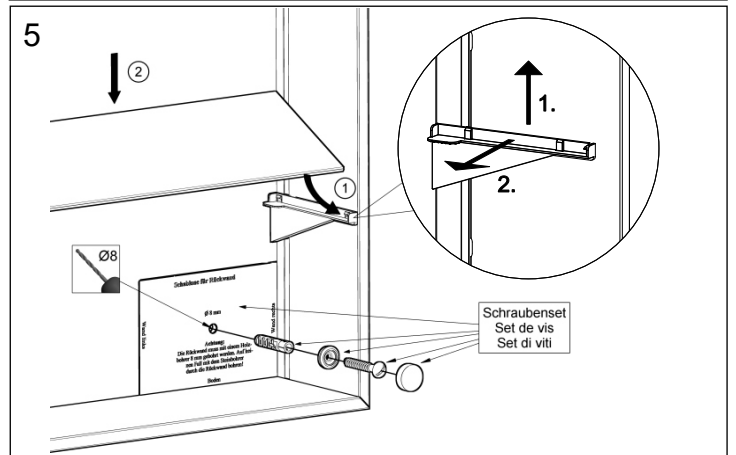
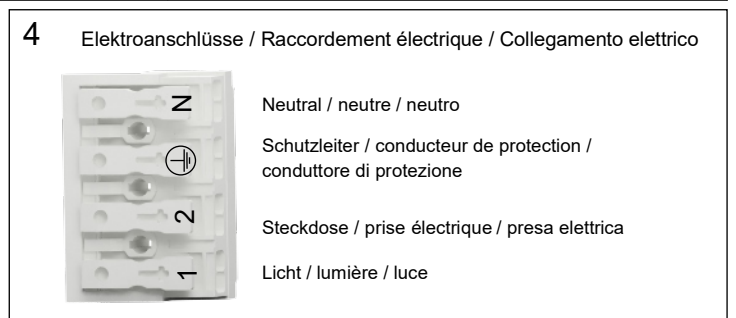
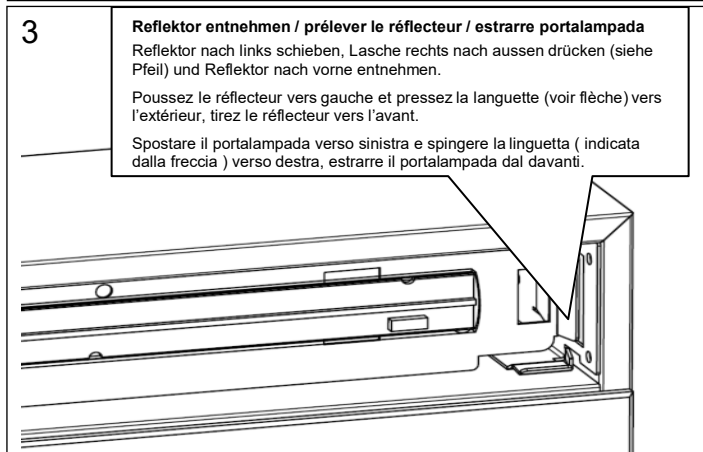
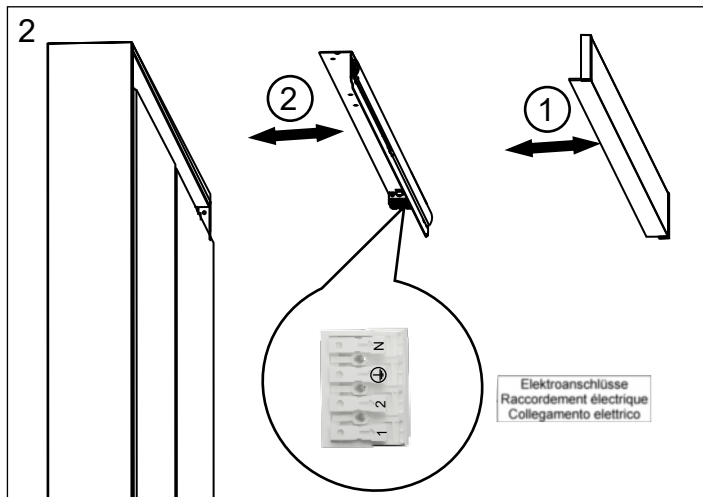
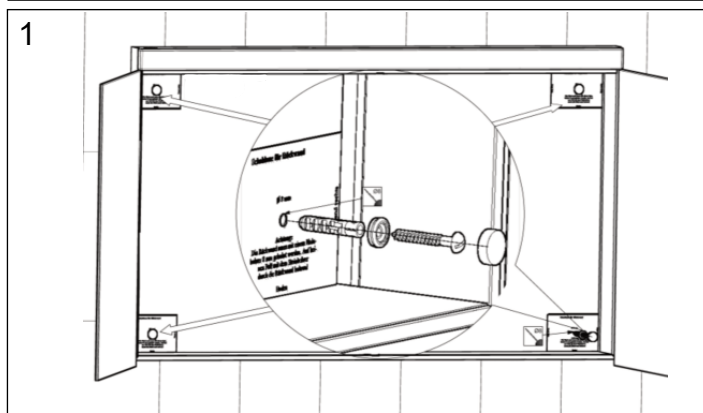
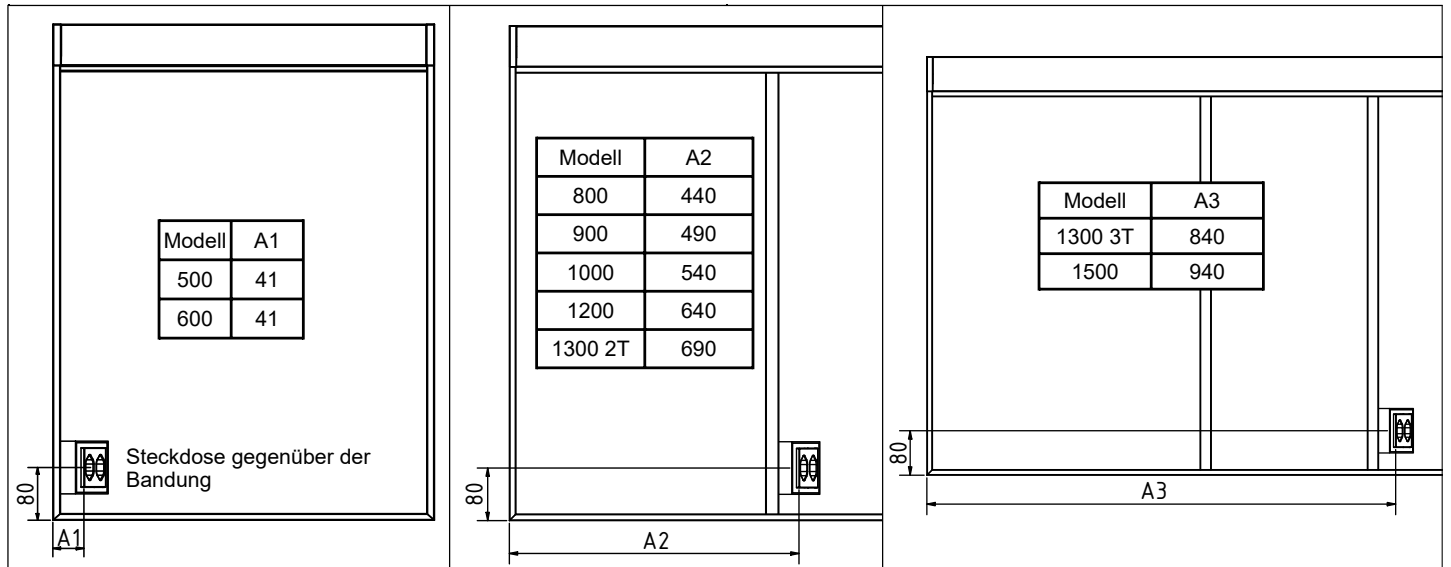

Alle Masse sind in mm angegeben. / Toutes les mesures sont indiquées en mm. / Tutte le misure sono indicate in mm.