

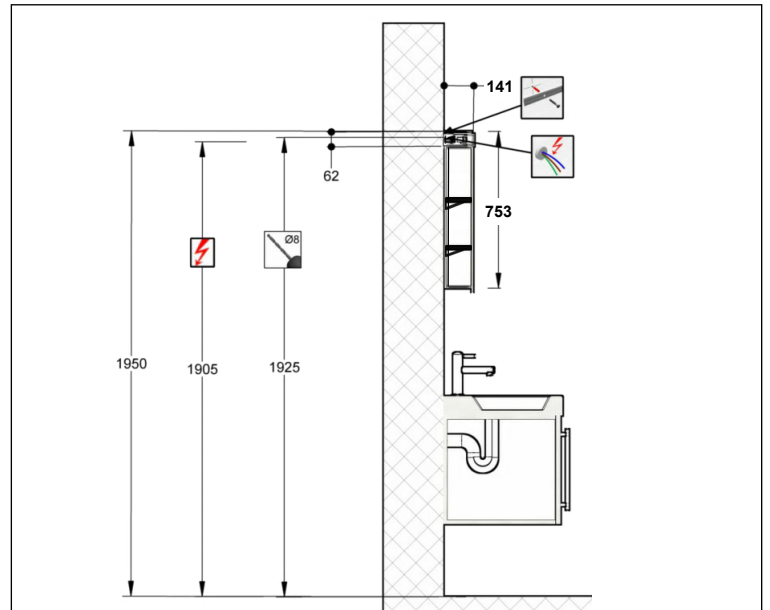

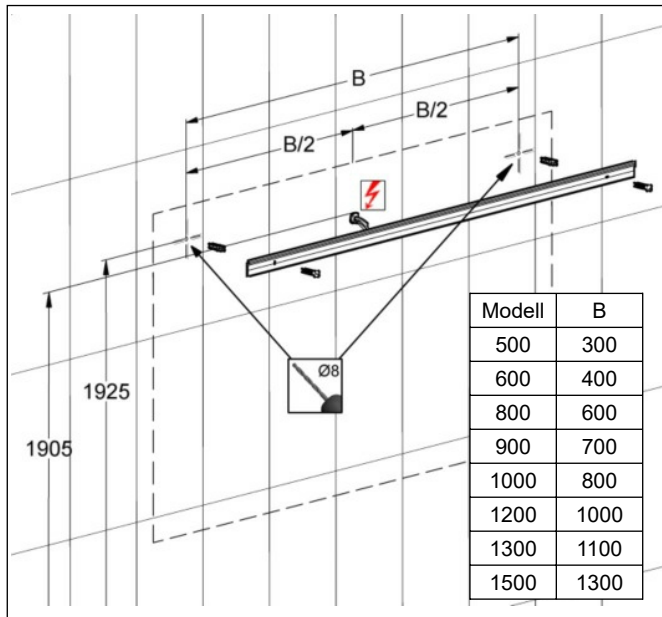

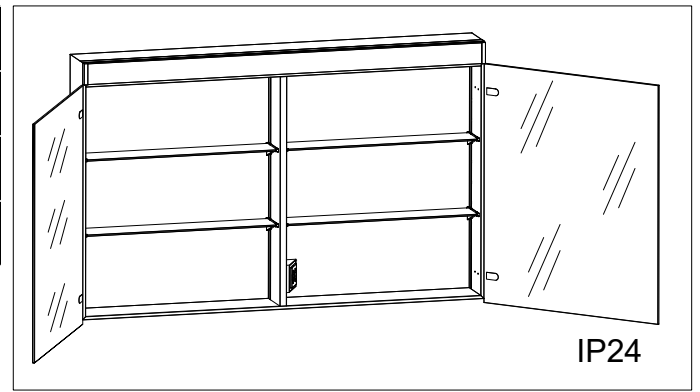





Massskizze / Montageanleitung PEARL

Fiche de mesure / Instruction de montage PEARL

Scheda misure / Istruzione di montaggio PEARL

640023 Keller Art. Nr. 108403173	PEARL 500/1T/BL PEARL 500/1P/CG PEARL 500/1P/CS	640029 Keller Art. Nr. 108403413	PEARL 1000/2T PEARL 1000/2P PEARL 1000/2P
640024 Keller Art. Nr. 108403183	PEARL 500/1T/BR PEARL 500/1P/CD PEARL 500/1P/CD	640030 Keller Art. Nr. 108403513	PEARL 1200/2T PEARL 1200/2P PEARL 1200/2P
640025 Keller Art. Nr. 108403013	PEARL 600/1T/BL PEARL 600/1P/CG PEARL 600/1P/CS	640031 Keller Art. Nr. 108403733	PEARL 1300/2T PEARL 1300/2P PEARL 1300/2P
640026 Keller Art. Nr. 108403023	PEARL 600/1T/BR PEARL 600/1P/CD PEARL 600/1P/CD	640032 Keller Art. Nr. 108403813	PEARL 1500/3T PEARL 1500/3T PEARL 1500/3T
640027 Keller Art. Nr. 108403073	PEARL 800/2T PEARL 800/2P PEARL 800/2P		
640028 Keller Art. Nr. 108403313	PEARL 900/2T PEARL 900/2P PEARL 900/2P		



Die Montage des Spiegelschranks muss durch einen Fachmann im Sanitärbereich erfolgen. Arbeiten an den elektrischen Installationen dürfen nur von autorisierten Fachleuten nach den örtlichen Vorschriften ausgeführt werden. Für nicht fachgerechte Installation wird jegliche Haftung abgelehnt. Räume mit Badewanne ① oder Dusche ① müssen mit einer FI-Schutzeinrichtung (RCD) I Δ n = 30mA gesichert sein. Bereich ② mindestens Schutzart IP X4. Bereich ② keine Steckdosen.

Le montage de l'armoire de toilette doit être effectué par un spécialiste autorisé en équipement sanitaire. Les travaux à l'installation électrique ne doivent pas être effectués que par des spécialistes autorisés selon les prescriptions locales. Si l'installation n'est pas faite par un expert nous déclinons toute responsabilité. Locaux avec baignoire ① ou douche ① doivent être protégés par un dispositif de protection FI (RCD) I Δ n = 30mA. Volume ② mind. degré de protection IP X4. Volume ② des prises électriques ne sont pas permises.

Il montaggio dell'armadietto da bagno deve essere eseguito da personale autorizzato del settore impianti sanitari. L'installazione elettrica deve essere eseguita da personale autorizzato secondo le norme vigenti del posto. Se l'installazione non viene eseguita dal personale autorizzato decliniamo ogni responsabilità. Ambienti con vasca da bagno ① o doccia ① devono essere protetti con un dispositivo di protezione FI (RCD) I Δ n = 30mA. Zona ② come minimo sistema di protezione IP X4. Zona ② non sono autorizzate le prese di corrente.

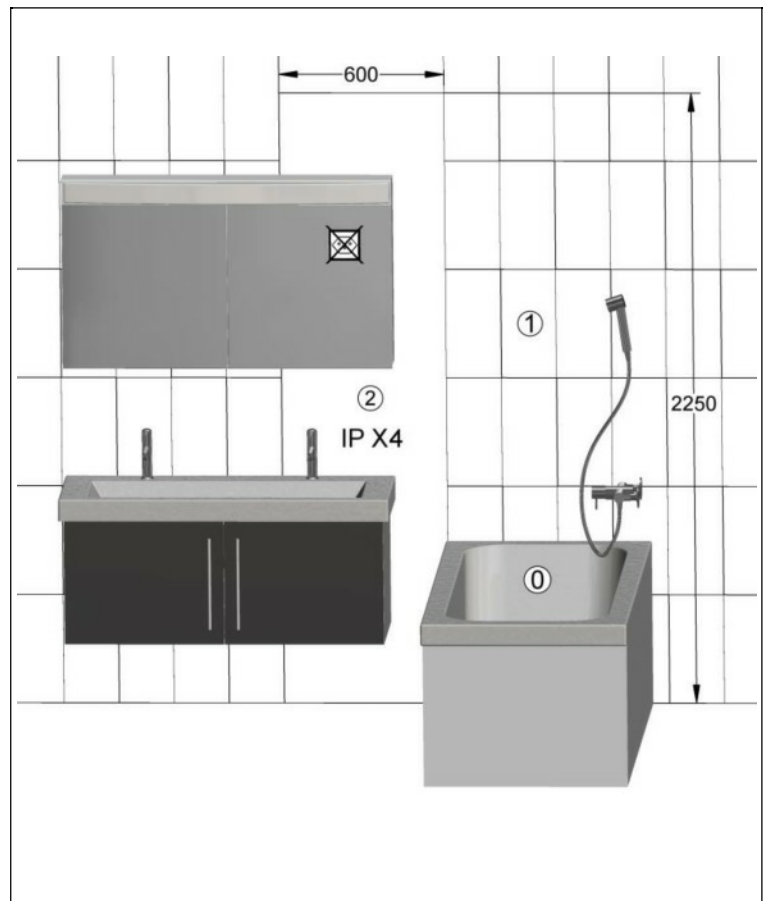

Alle Masse sind in mm angegeben. / Toutes les mesures sont indiquées en mm. / Tutte le misure sono indicate in mm.

Massskizze / Montageanleitung PEARL

Fiche de mesure / Instruction de montage PEARL

Scheda misure / Istruzione di montaggio PEARL

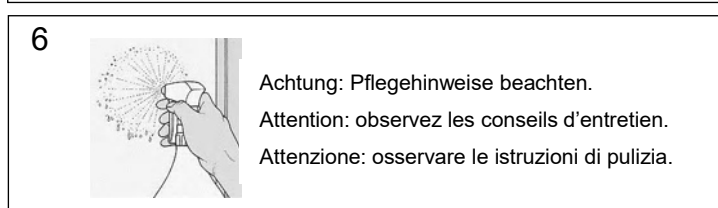
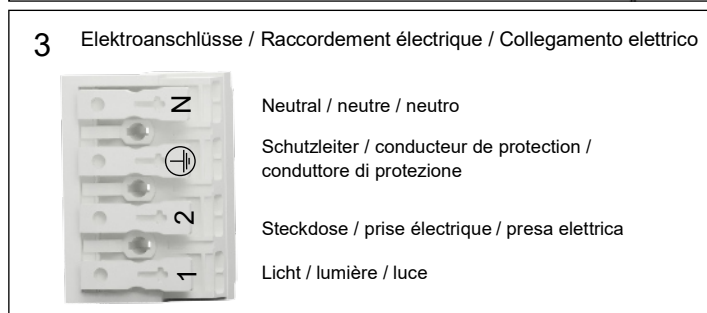
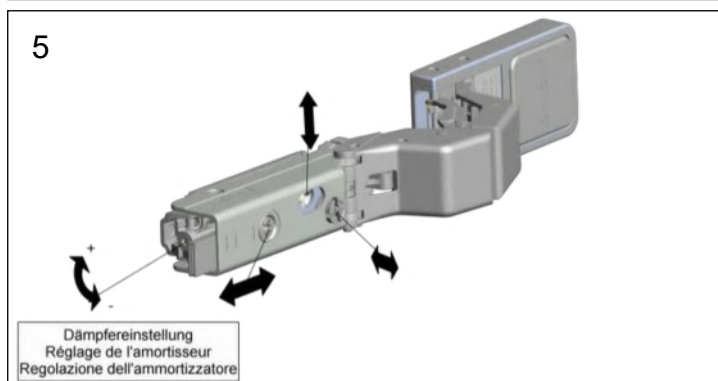
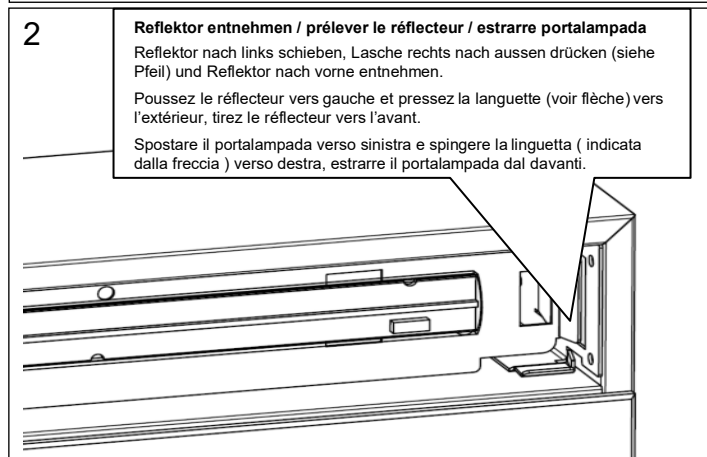
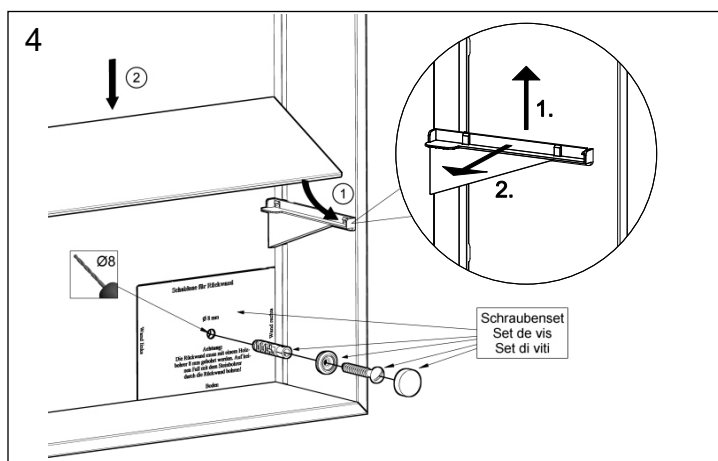
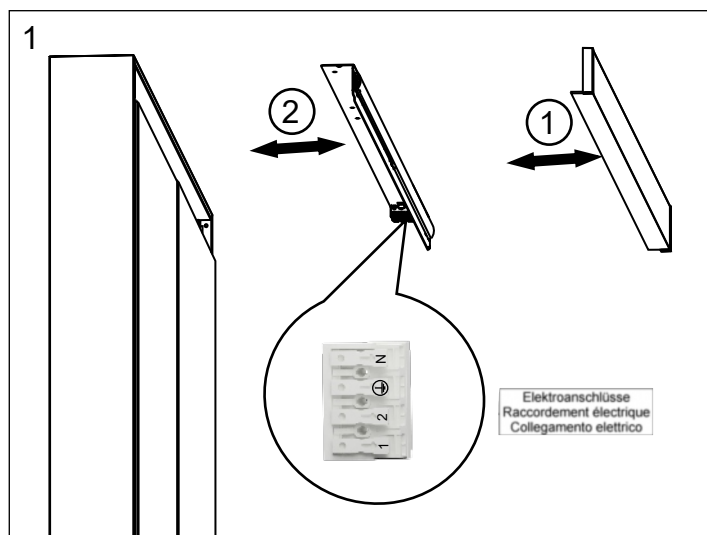
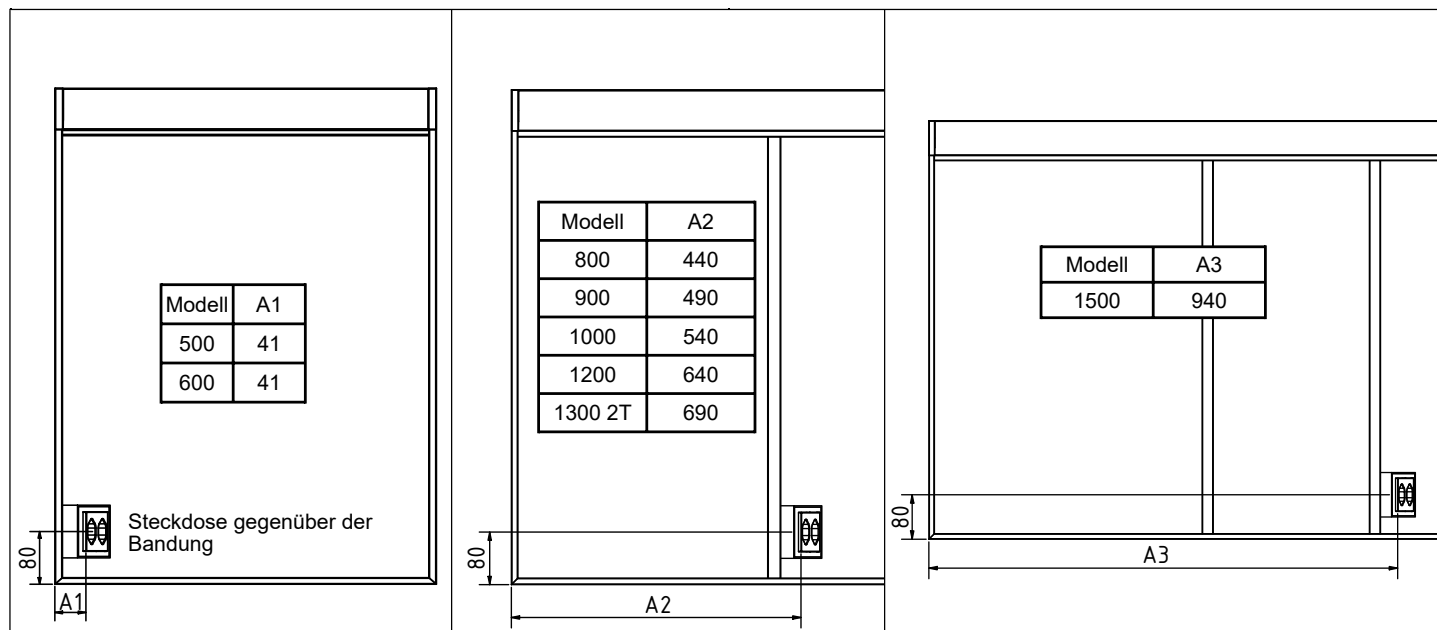

Alle Masse sind in mm angegeben. / Toutes les mesures sont indiquées en mm. / Tutte le misure sono indicate in mm.

Massskizze / Montageanleitung Wandeinbau PEARL

Fiche de mesure / Instruction de montage pour l'encastrement PEARL

Istruzione di montaggio ad incasso PEARL

640023 Keller Art. Nr. 108403173	PEARL 500/1T/BL PEARL 500/1P/CG PEARL 500/1P/CS	640029 Keller Art. Nr. 108403413	PEARL 1000/2T PEARL 1000/2P PEARL 1000/2P
640024 Keller Art. Nr. 108403183	PEARL 500/1T/BR PEARL 500/1P/CD PEARL 500/1P/CD	640030 Keller Art. Nr. 108403513	PEARL 1200/2T PEARL 1200/2P PEARL 1200/2P
640025 Keller Art. Nr. 108403013	PEARL 600/1T/BL PEARL 600/1P/CG PEARL 600/1P/CS	640031 Keller Art. Nr. 108403733	PEARL 1300/2T PEARL 1300/2P PEARL 1300/2P
640026 Keller Art. Nr. 108403023	PEARL 600/1T/BR PEARL 600/1P/CD PEARL 600/1P/CD	640032 Keller Art. Nr. 108403813	PEARL 1500/3T PEARL 1500/3T PEARL 1500/3T
640027 Keller Art. Nr. 108403073	PEARL 800/2T PEARL 800/2P PEARL 800/2P		
640028 Keller Art. Nr. 108403313	PEARL 900/2T PEARL 900/2P PEARL 900/2P		

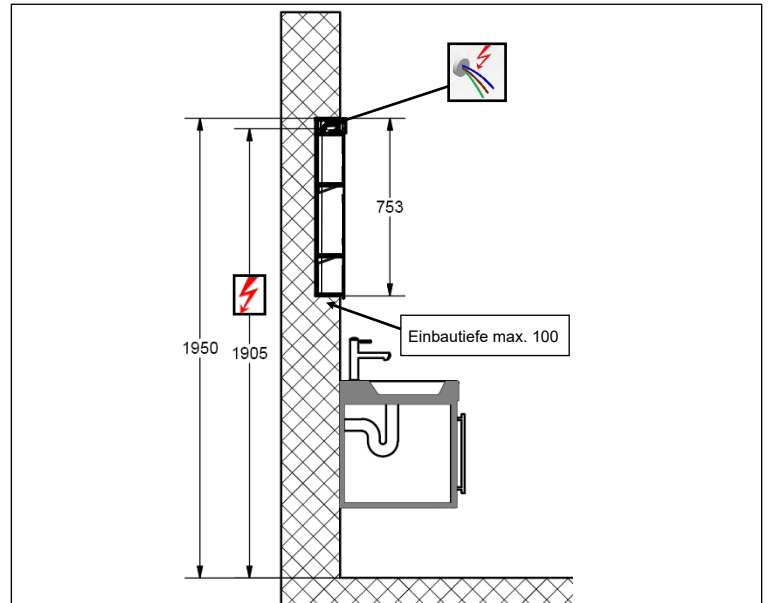
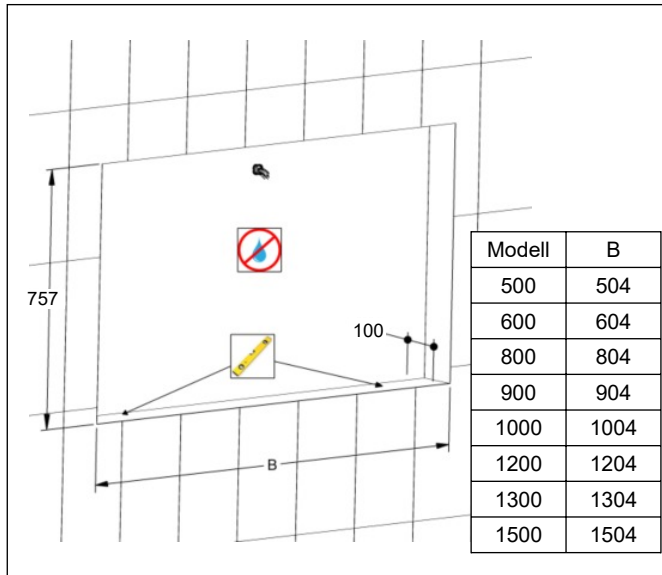
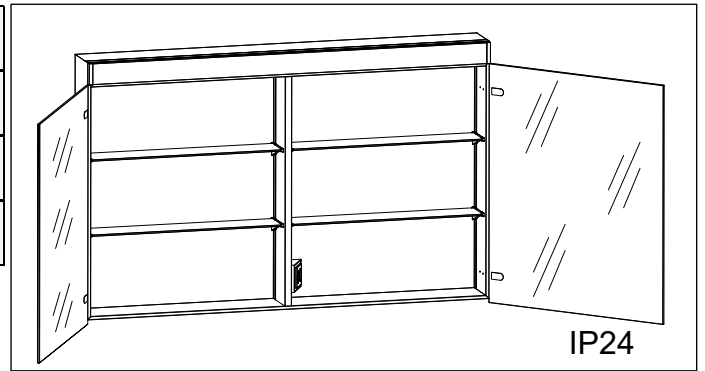

Die Montage des Spiegelschranks muss durch einen Fachmann im Sanitärbereich erfolgen. Arbeiten an den elektrischen Installationen dürfen nur von autorisierten Fachleuten nach den örtlichen Vorschriften ausgeführt werden. Für nicht fachgerechte Installation wird jegliche Haftung abgelehnt. Räume mit Badewanne ① oder Dusche ① müssen mit einer FI-Schutzeinrichtung (RCD) I Δ n = 30mA gesichert sein. Bereich ② mindestens Schutzart IP X4. Bereich ② keine Steckdosen.

Le montage de l'armoire de toilette doit être effectué par un spécialiste autorisé en équipement sanitaire. Les travaux à l'installation électrique ne doivent pas être effectués que par des spécialistes autorisés selon les prescriptions locales. Si l'installation n'est pas faite par un expert nous déclinons toute responsabilité. Locaux avec baignoire ① ou douche ① doivent être protégés par un dispositif de protection FI (RCD) I Δ n = 30mA. Volume ② mind. degré de protection IP X4. Volume ② des prises électriques ne sont pas permises.

Il montaggio dell'armadietto da bagno deve essere eseguito da personale autorizzato del settore impianti sanitari. L'installazione elettrica deve essere eseguita da personale autorizzato secondo le norme vigenti del posto. Se l'installazione non viene eseguita dal personale autorizzato decliniamo ogni responsabilità. Ambienti con vasca da bagno ① o doccia ① devono essere protetti con un dispositivo di protezione FI (RCD) I Δ n = 30mA. Zona ② come minimo sistema di protezione IP X4. Zona ② non sono autorizzate le prese di corrente.

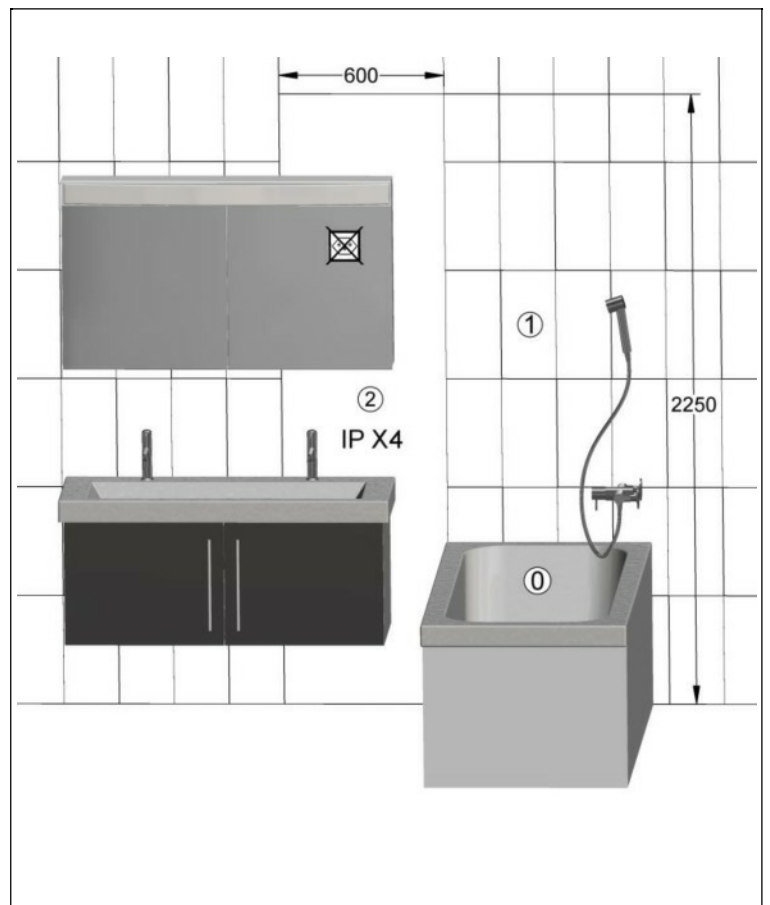

Alle Masse sind in mm angegeben. / Toutes les mesures sont indiquées en mm. / Tutte le misure sono indicate in mm.

